

There are several notes I need to provide to aid you with the enclosed package. The original kits used 1/16" balsa. Since I wanted to print these directly on balsa sheet I developed the parts for 1/32" balsa sheet. As a result, some of the parts have been drawn to allow for cross grain laminations. The fuselage formers are a good example. This works fine as long as you are using 1/32" sheet stock.

If you do not have a printer that will allow direct printing on the balsa, consider using the iron on T-shirt transfer paper layouts provided via the parmodels.com web site. This material can be printed on any color inkjet printer. You can then transfer the part graphics to balsa sheet of any thickness using a regular clothes iron.

I like to use a removable nose for winding. The parts have been drawn with this in mind. The nose former has been drawn so a removable nose plug can be used. The FrogFlite series of models provides a piece of 1/4" balsa for the nose block. The piece of balsa had to be cut to shape and then sanded to the nose profile. A template has been provided to aid cutting the nose block to the shape of the nose.

The kit included reinforcements for the rear motor peg. The parts in this package include the same rear motor peg reinforcement parts. The only difference is two sets of those parts are included to allow for models build from 1/32" balsa were parts are laminated to be 1/16" in thickness. This has proven to be plenty strong for a fully wound motor of 1/8" Tan rubber. A piece of 3/32" OD aluminum tubing is used for the rear motor peg.

A few minor structural changes were made for the reproduction model. Fuselage partial former D was replaced with a full depth former. This makes bending the fuselage sides much easier and strengthens the fuselage where it is typically held for hand launching. Landing gear leg covers have also been added to give the model a more finished look.

The markings used in the original Puss Moth kit were retained for this reproduction package. Some enhancements are included. For example, the original kit parts only had one color applied to the balsa sheets. Where the kit left the balsa bare the appropriate color as shown in the box art was added to the reproduction model parts.

I do hope you build and enjoy a model from this plan package.

Paul Bradley

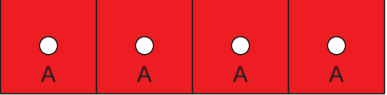
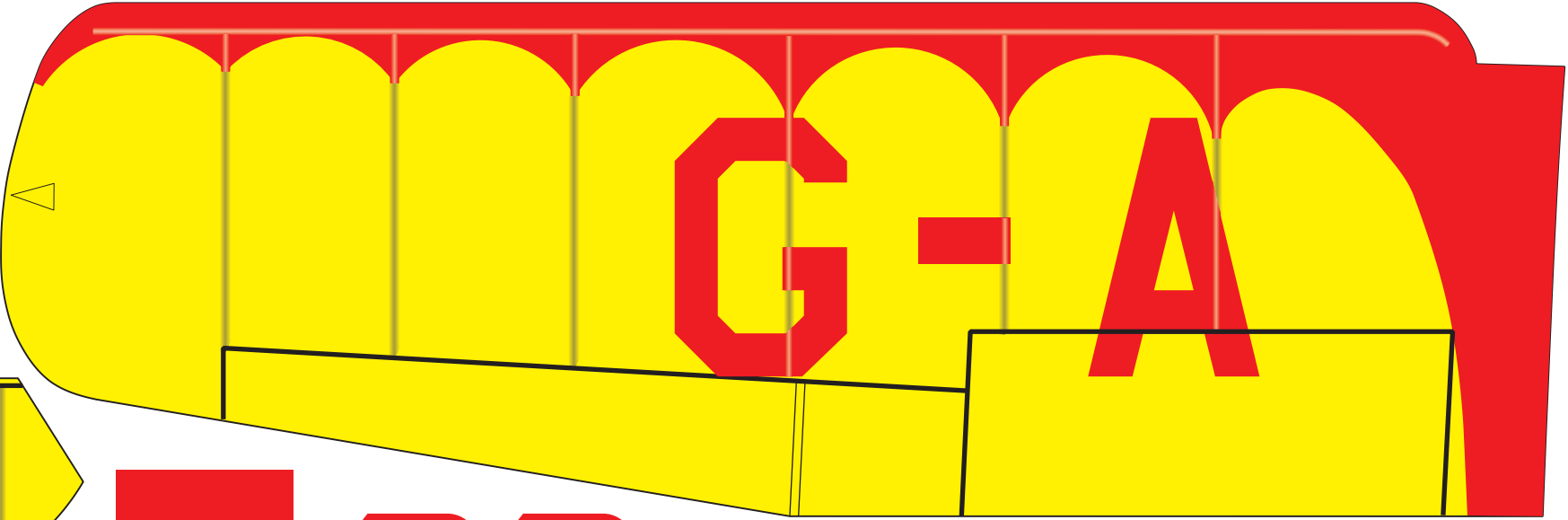
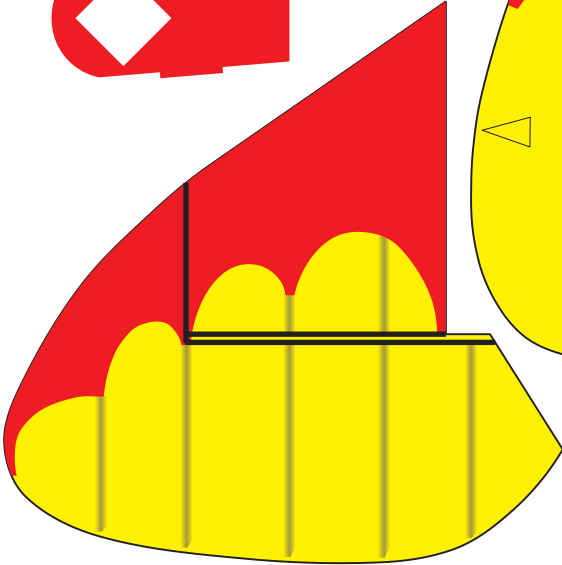
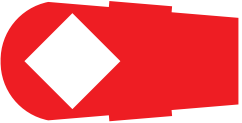
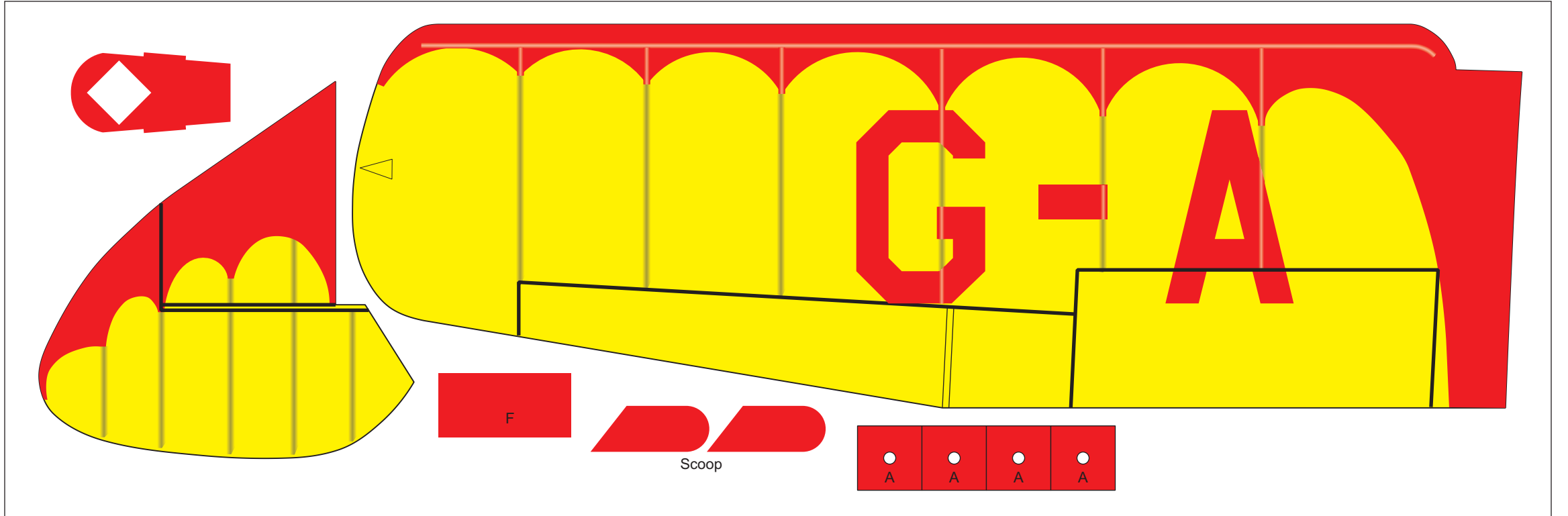

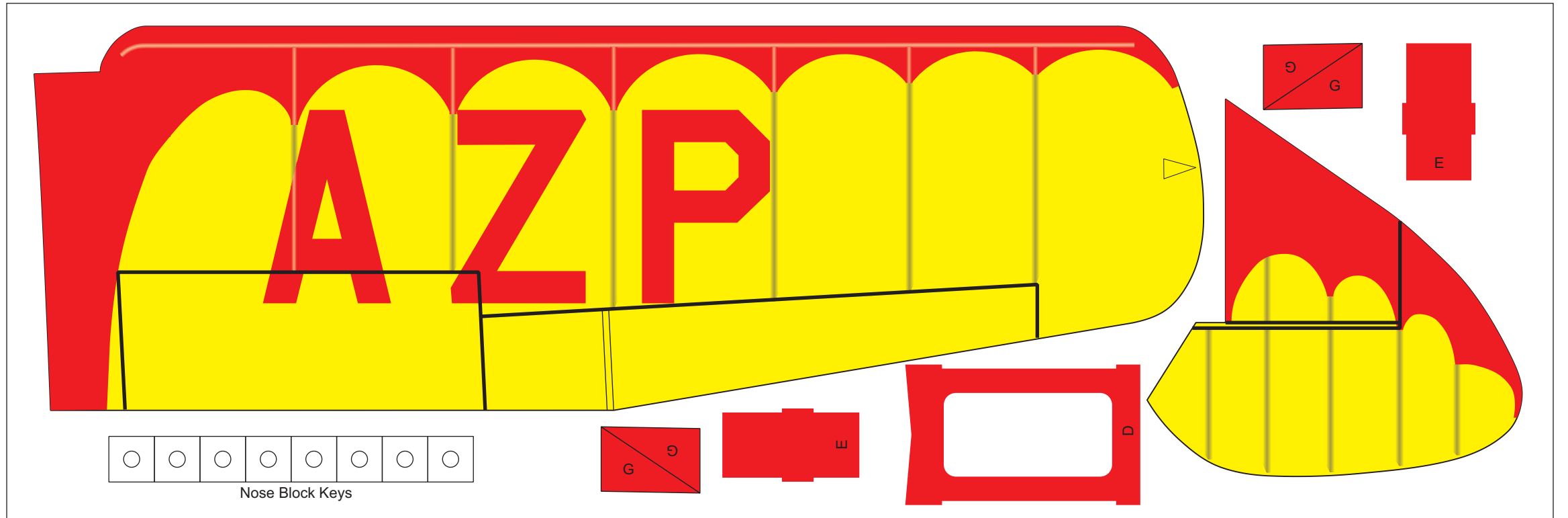

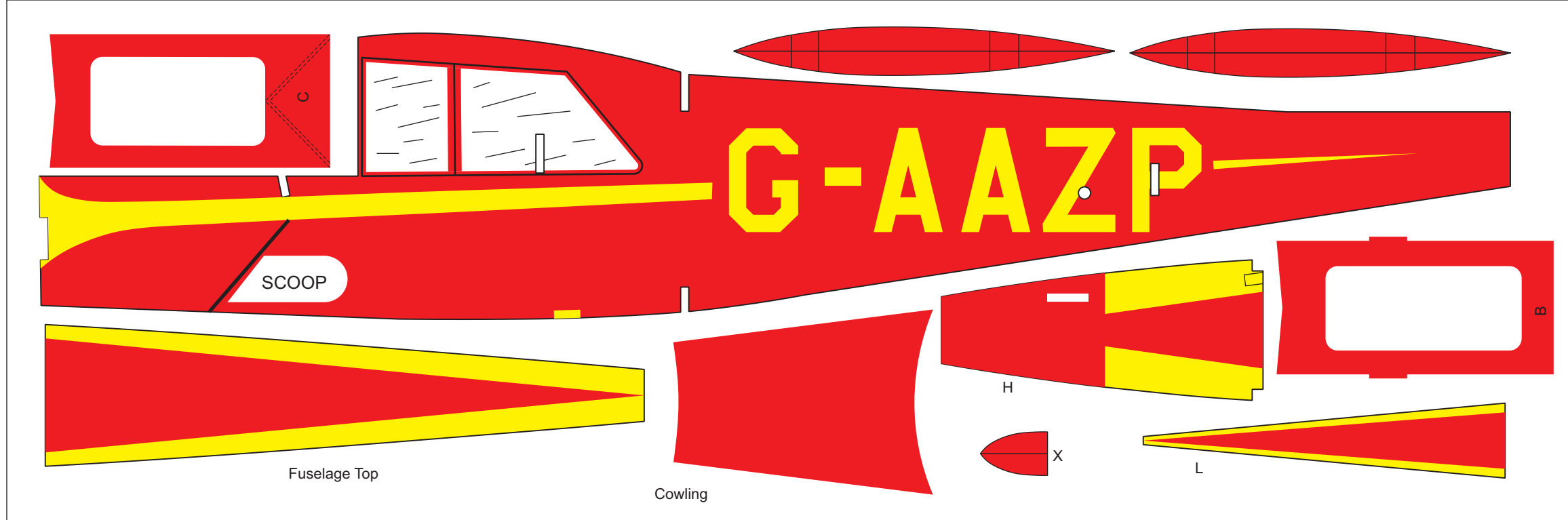

Fuselage Top

Cowling

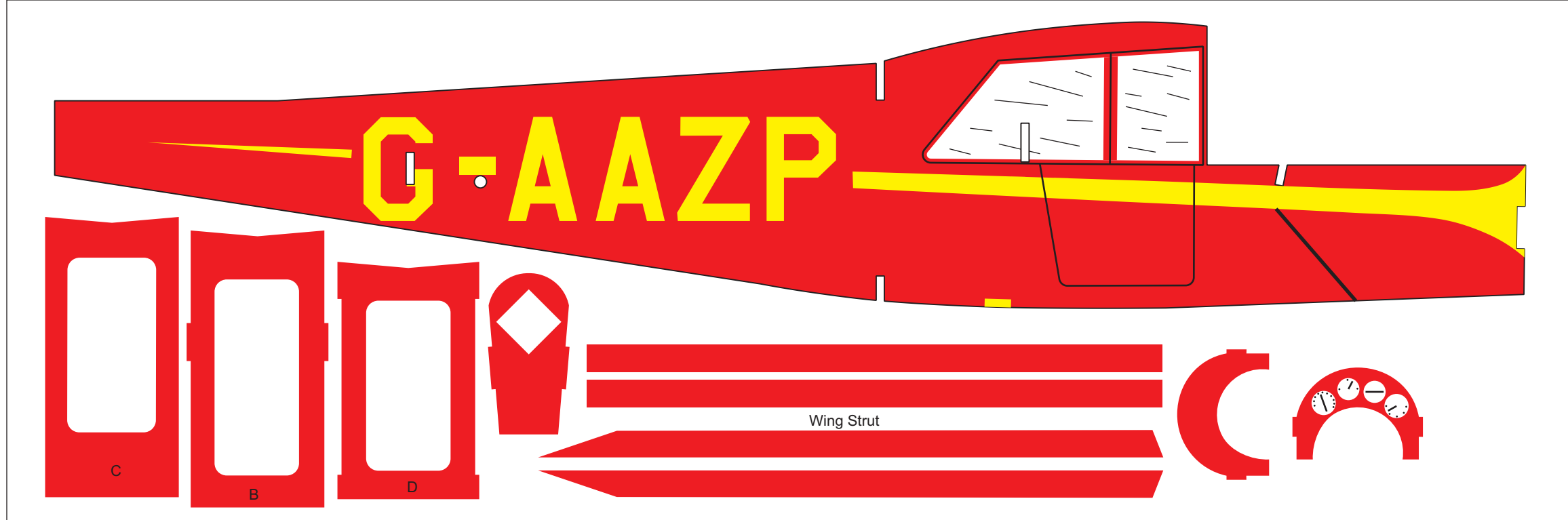

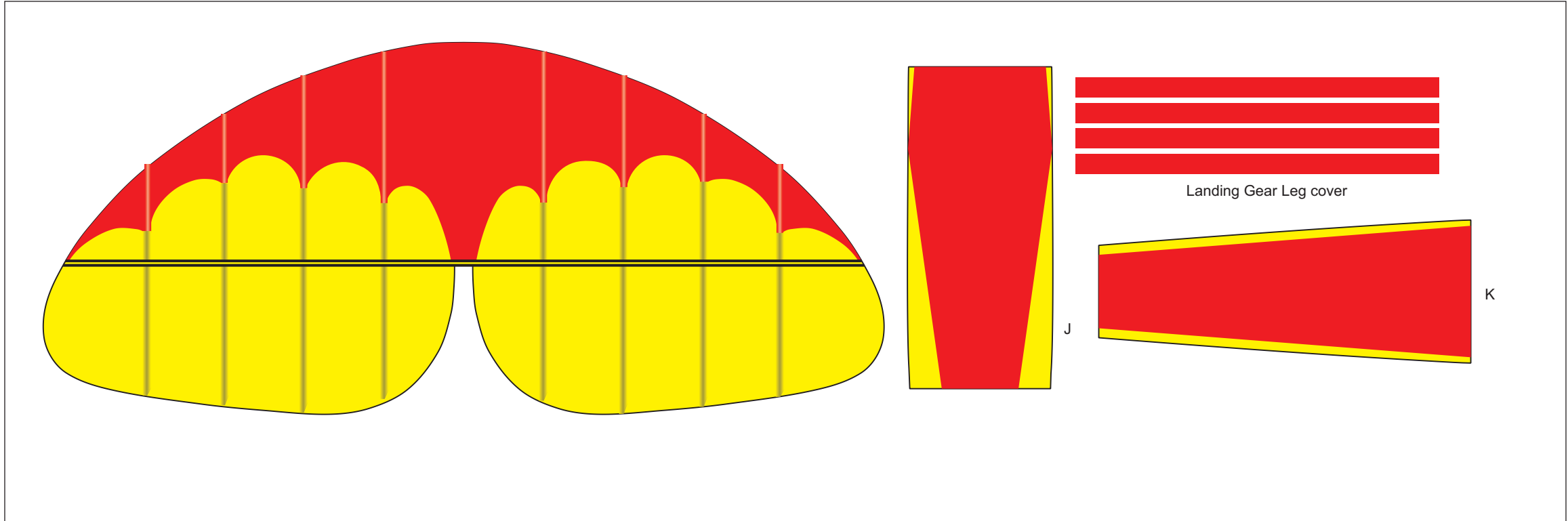

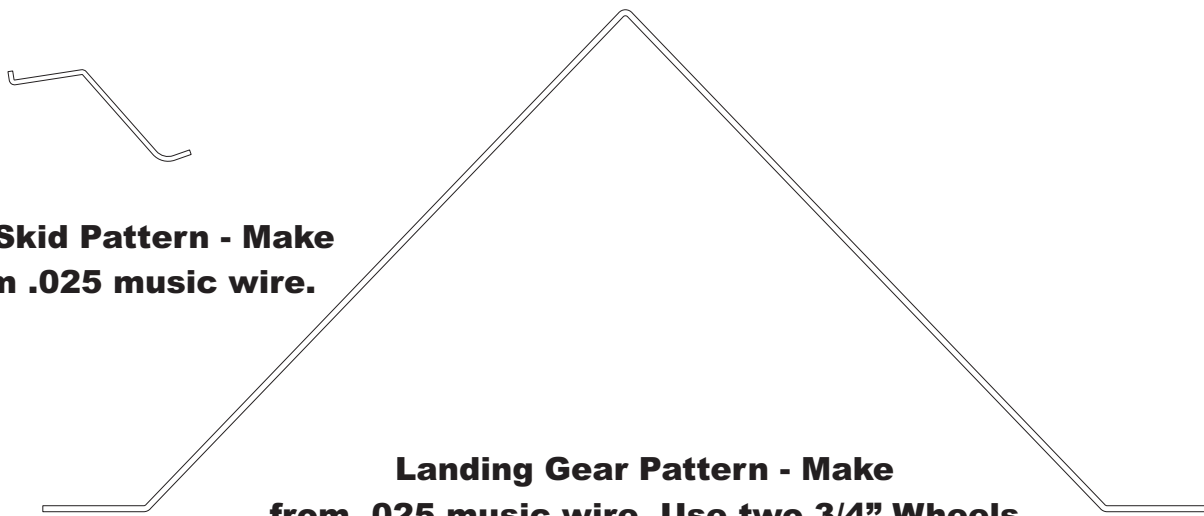

Tail Skid Pattern - Make from .025 music wire.

Landing Gear Pattern - Make from .025 music wire. Use two 3/4" Wheels

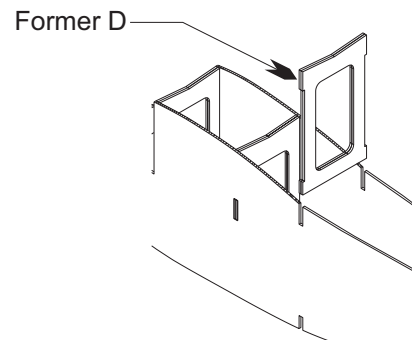

Former D in plan step 5 is full depth as opposed to the partial former shown on the plan.

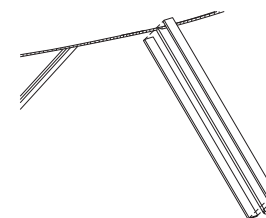

Landing gear leg covers have been provided. They sandwich the wire landing gear legs as shown.

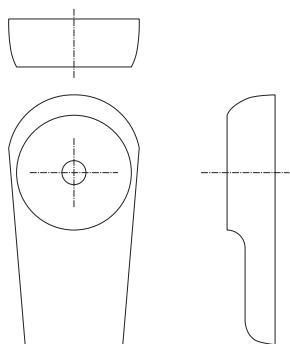

Nose Block - Make from 1/4" balsa

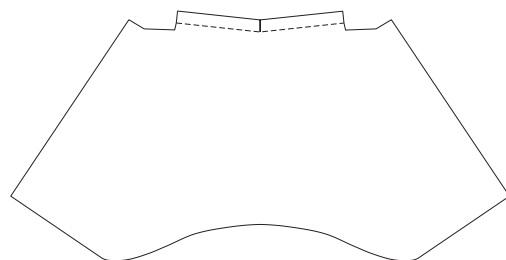

Windshield Pattern

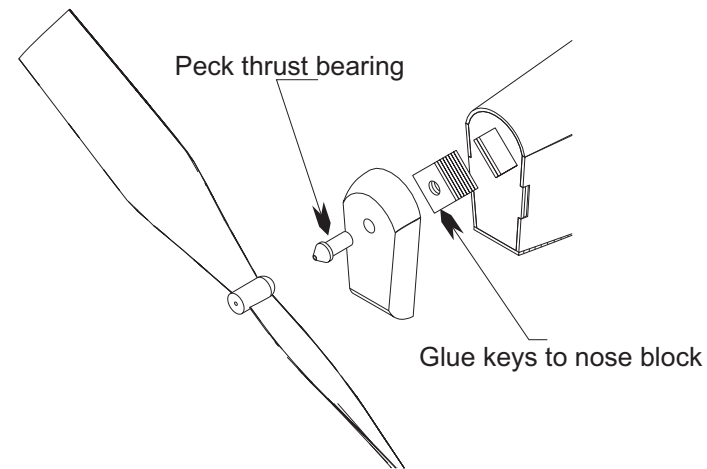

The nose block is removable for stretch winding as opposed to the fixed block shown on the kit plan. The nose block is made from 1/4" balsa. Glue the laminated key block to the rear face of the nose block.

FrogFlite Puss Moth

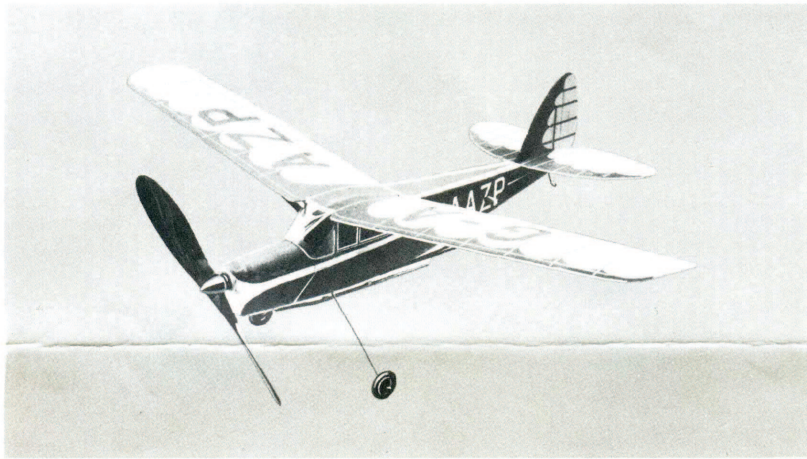

HALES

QuickBuild SERIES
RUBBER POWERED FLYING SCALE MODELS

FROGFLITE KITS

DESIGNED AND DRAWN BY RON WARRING COPYRIGHT IN ALL COUNTRIES
MANUFACTURED IN ENGLAND BY:

BY A. A. HALES LTD. HINCKLEY, LEICS.

PUSS MOTH

IMPORTANT: CHECK AND IDENTIFY YOUR KIT PARTS

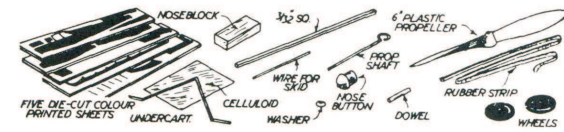

YOUR ASSEMBLY INSTRUCTIONS

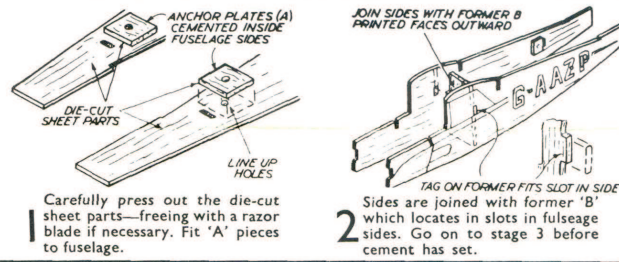

1 Carefully press out the die-cut sheet parts—freeing with a razor blade if necessary. Fit 'A' pieces to fuselage.

2 Sides are joined with former 'B' which locates in slots in fuselage sides. Go on to stage 3 before cement has set.

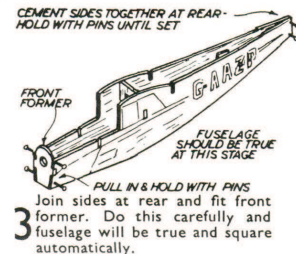

3 Join sides at rear and fit front former. Do this carefully and fuselage will be true and square automatically.

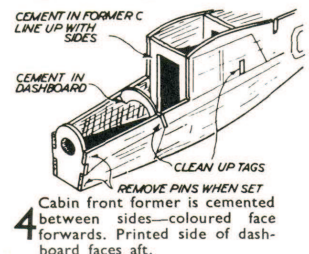

4 Cabin front former is cemented between sides—coloured face forwards. Printed side of dashboard faces aft.

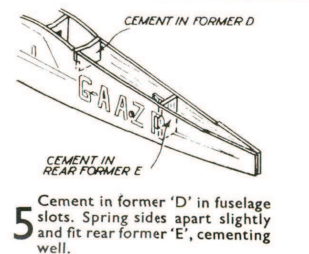

5 Cement in former 'D' in fuselage slots. Spring sides apart slightly and fit rear former 'E', cementing well.

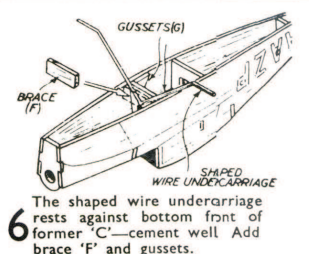

6 The shaped wire undercarriage rests against bottom front of former 'C'—cement well. Add brace 'F' and gussets.

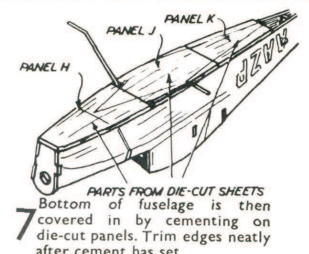

7 Bottom of fuselage is then covered in by cementing on die-cut panels. Trim edges neatly after cement has set.

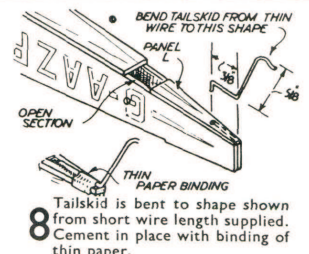

8 Tailskid is bent to shape shown from short wire length supplied. Cement in place with binding of thin paper.

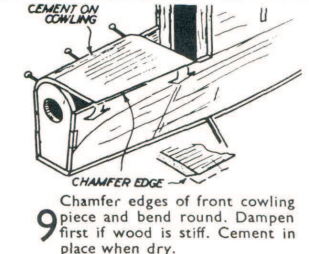

9 Chamfer edges of front cowling piece and bend round. Dampen first if wood is stiff. Cement in place when dry.

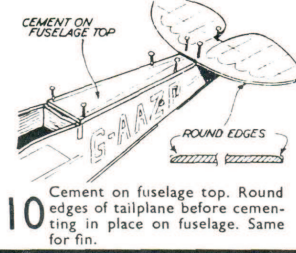

10 Cement on fuselage top. Round edges of tailplane before cementing in place on fuselage. Same for fin.

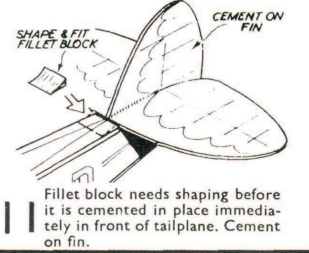

11 Fillet block needs shaping before it is cemented in place immediately in front of tailplane. Cement on fin.

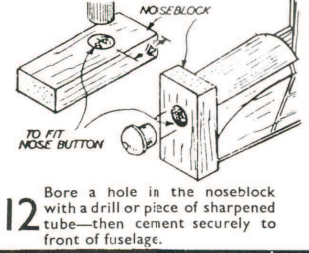

12 Bore a hole in the noseblock with a drill or piece of sharpened tube—then cement securely to front of fuselage.

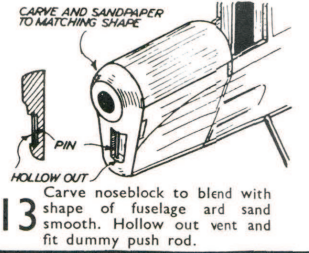

13 Carve noseblock to blend with shape of fuselage and sand smooth. Hollow out vent and fit dummy push rod.

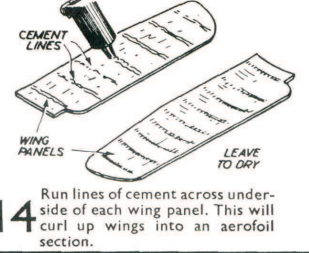

14 Run lines of cement across underside of each wing panel. This will curl up wings into an aerofoil section.

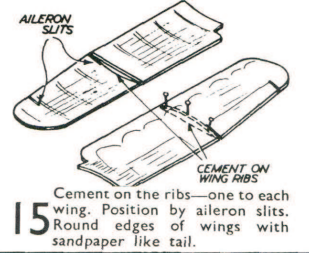

15 Cement on the ribs—one to each wing. Position by aileron slits. Round edges of wings with sandpaper like tail.

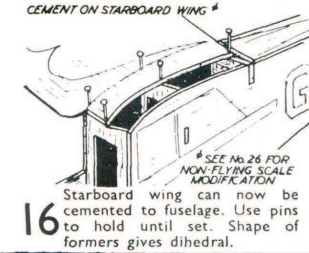

16 Starboard wing can now be cemented to fuselage. Use pins to hold until set. Shape of formers gives dihedral.

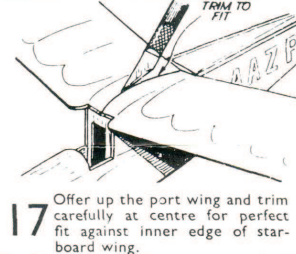

17 Offer up the port wing and trim carefully at centre for perfect fit against inner edge of starboard wing.

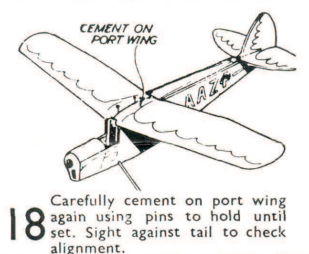

18 Carefully cement on port wing again using pins to hold until set. Sight against tail to check alignment.

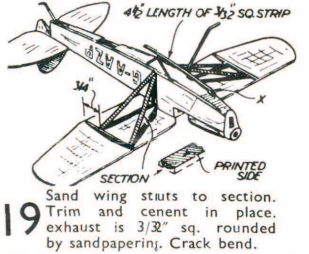

19 Sand wing struts to section. Trim and cement in place. Exhaust is 3/8" sq. rounded by sandpapering. Crack bend.

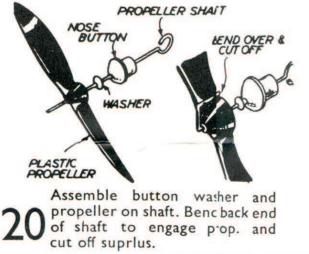

20 Assemble button washer and propeller on shaft. Bend back end of shaft to engage pop. and cut off surplus.

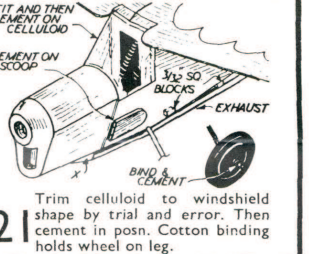

21 Trim celluloid to windshield shape by trial and error. Then cement in posn. Cotton binding holds wheel on leg.

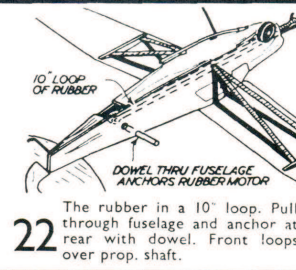
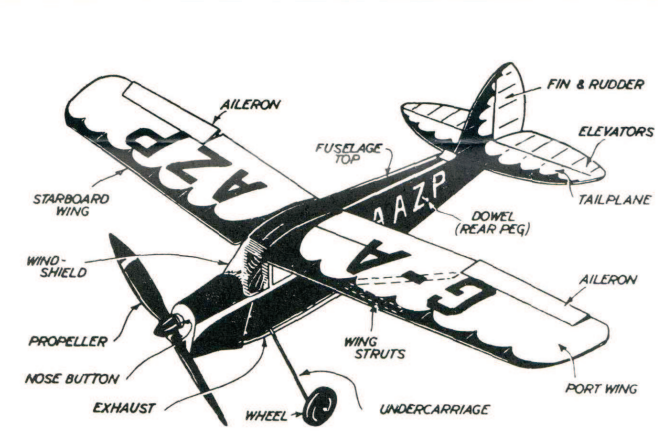

22 The rubber in a 10" loop. Pull through fuselage and anchor at rear with dowel. Front loops over prop. shaft.

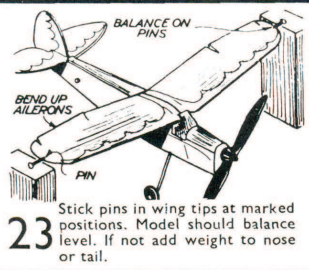

23 Stick pins in wing tips at marked positions. Model should balance level. If not add weight to nose or tail.

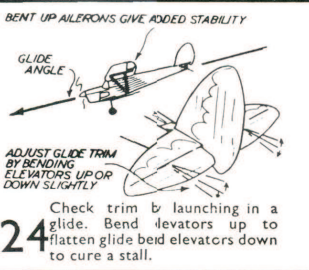

24 Check trim by launching in a glide. Bend elevators up to flatten glide bed elevators down to cure a stall.

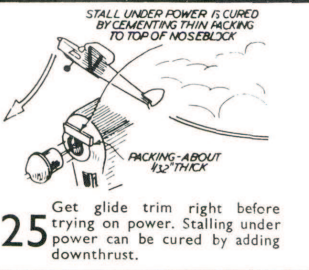

25 Get glide trim right before trying on power. Stalling under power can be cured by adding downthrust.

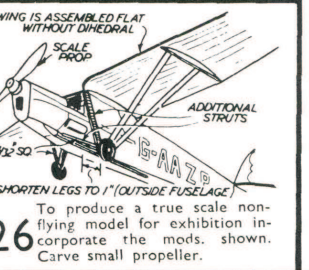

26 To produce a true scale non-flying model for exhibition incorporate the mods. shown. Carve small propeller.

FROGFLITE



HALES

Quick Build series
Rubber Powered Flying Scale Models

PUSS MOTH

