

PIPER CUB

20" WINGSPAN FLYING MODEL

Design, art, plan, engineering and original model by -

Jim Newman

MIDWEST PRODUCTS CO. HOBART, IND.

IDENTIFY AND CHECK YOUR PARTS :

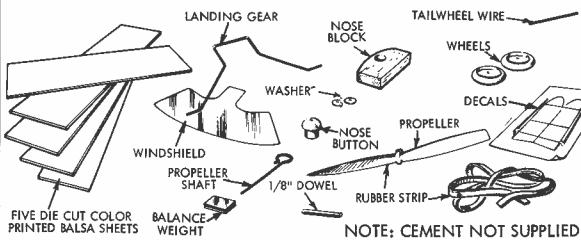

NOTE: CEMENT NOT SUPPLIED

Follow these steps for EASY BUILDING!

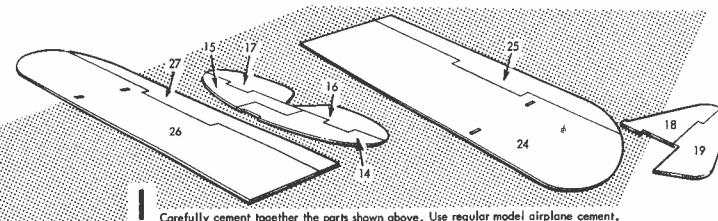

Carefully cement together the parts shown above. Use regular model airplane cement.

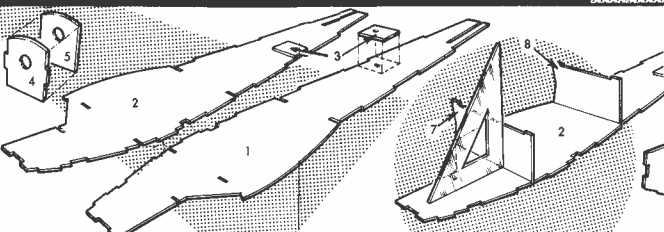

2 Lay parts 1 and 2 color side down and carefully cement together parts pictured.

3 Cement 7 and 8 to side 2. Use triangle to get them upright.

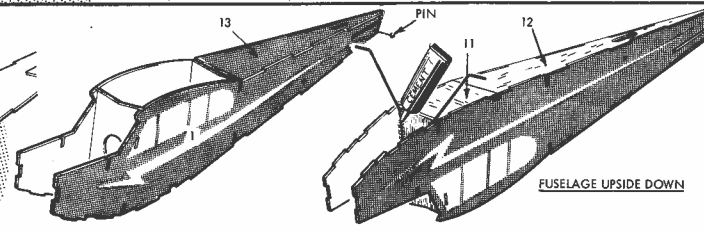

4 Cement side 1 to 7 and 8. Accurately cement sides together at rear - hold with pin. Cement top part, 13.

5 Turn fuselage over and cement 11 and 12 in place. Firmly cement landing gear to front of 7.

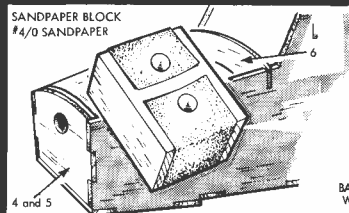

6 Pull sides of nose together then cement in 4 and 5. Be sure 5 is facing rear. Cement 6 in place then sand level on sides.

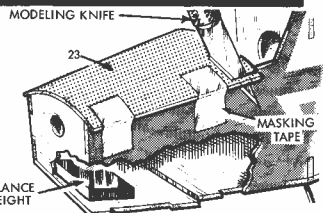

7 Cement 9 and 10 in place and firmly cement balance weight inside nose. Cement on 23 and hold with masking tape. Carefully trim off excess with sharp knife.

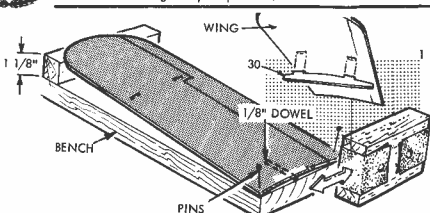

8 Cement rib 30 under each wing to give curvature. Pin wings to edge of bench. Prop up ribs and sand end of wing as shown.

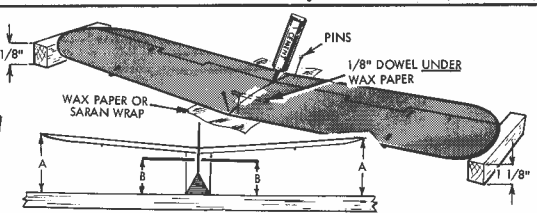

9 Cement ends of wings then pin and support as shown until set. Cement wing and tail to fuselage then look at model from rear. Line up wing and tail before glue dries.

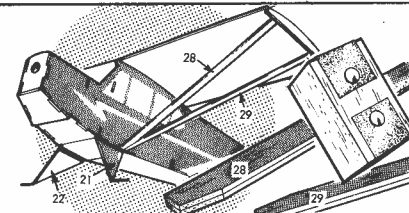

10 Cement together 28's and 29's, color side out. Sand edges round then cement into fuselage holes and against ribs. Cement 21 and 22 to landing gear.

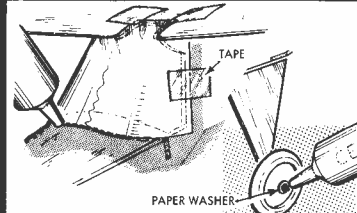

11 Tape windshield in place and cement around edge. Cut small paper washers and cement to axles to retain wheels.

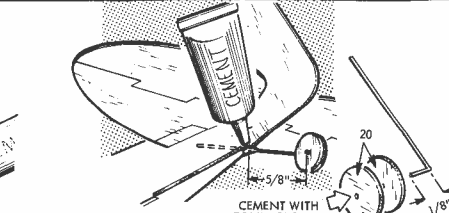

12 Make tailwheel as pictured. Cement wheel to wire, push into tail end and cement securely.

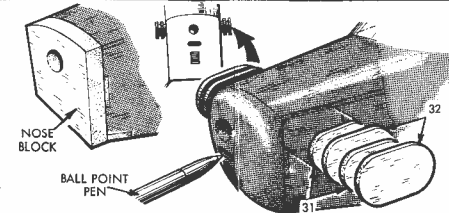

13 Cement noseblock to 4, round off corners and draw intake. Make engine with 31's and 32's. Paint block and cement each side of nose.

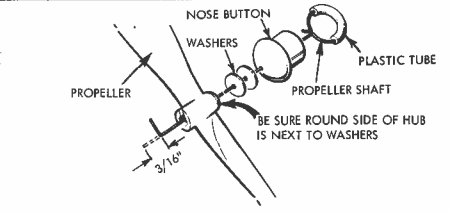

14 Assemble propeller as in picture. Bend end of shaft 90° and slip plastic tube from electrical wire over hook to protect rubber.

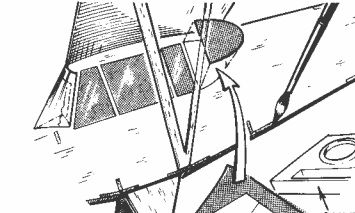

15 Peel window decals and numbers from backing sheet and apply to model. Use your paint box to touch up edges of bare wood.

PREPARING THE RUBBER MOTOR

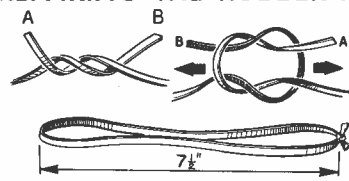

1 Join ends of rubber with square knot to make loop.

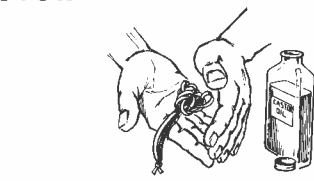

2 Put small drop of castor oil in palm of hand. Rub motor between hands KEEPING OIL OFF KNOT or it may slip open.

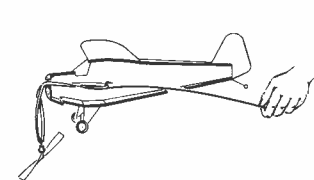

3 Use florist's wire or solder to pull rubber through model. Keep knot to rear.

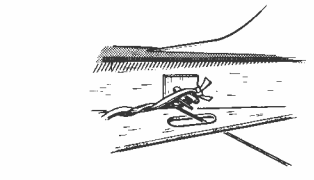

4 Before unhooking wire, push dowel through fuselage, making sure it goes through rubber loop.

FLYING INSTRUCTIONS

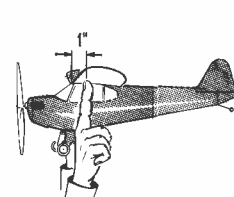

1 Balance model on fingertips. Add modeling clay under nose or tail until it stays level.

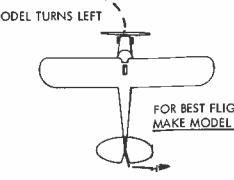

3 Control turning by bending rudder. Aim for a wide circle.

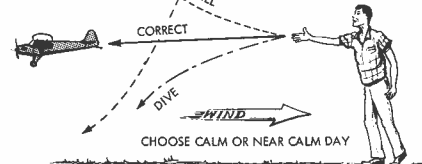

2 Launch level and smoothly. If model climbs sharply then dives (stalls), bend rear edge of stabilizer down a little or put clay under nose. If it dives, bend it up or put clay under tail. Continue until smooth glide is obtained.

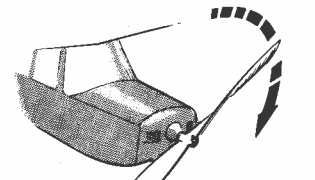

4 Turn propeller in direction shown to wind up rubber 150 turns for average 10 second trip.

We have put a lot of effort into making sure that each of our models gives you maximum enjoyment in assembly and flying. After this model we are sure you will want to build the other exciting airplanes in the same range and which are pictured below.

Why not send for catalog showing the remainder of our products? Use the handy coupon below.

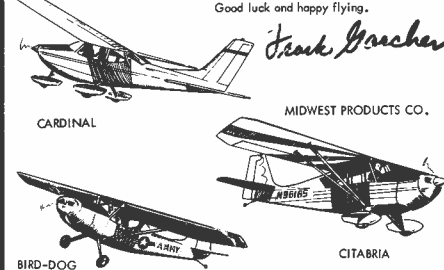

Please send me your illustrated catalog of models and accessories. I enclose 25¢ to cover cost.

Name _____ Address _____
 City _____ State _____ Zip _____

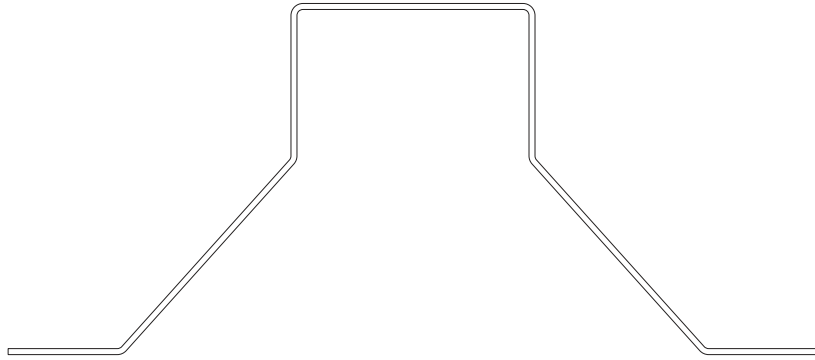

Landing Gear Pattern - Make from .032 music wire. Use 1" Wheels

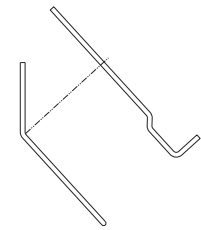

Tail Wheel Leg Pattern - Make from .025 music wire

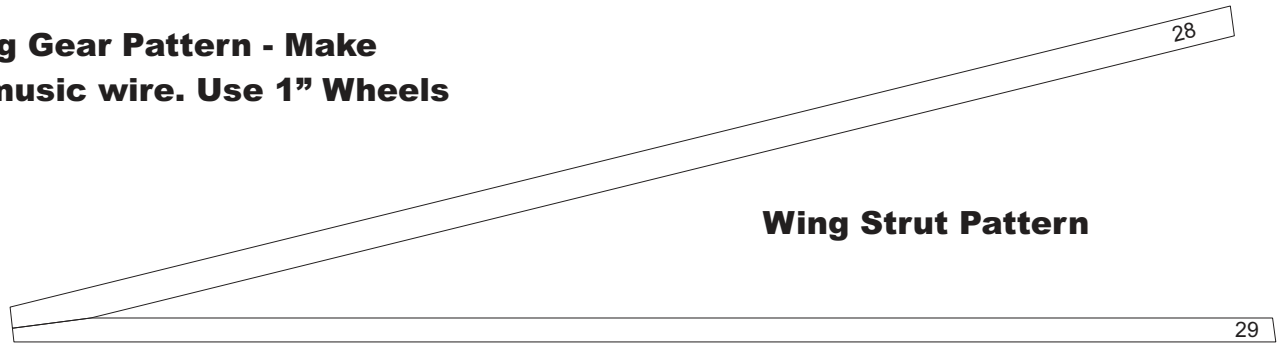

Wing Strut Pattern

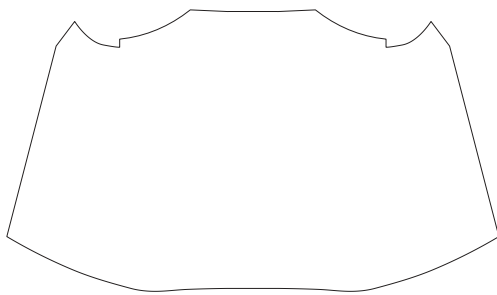

Windshield Pattern

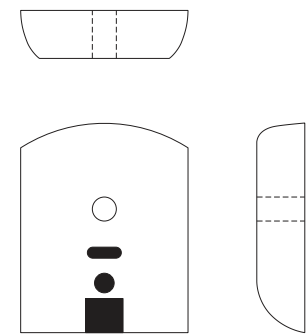

Nose Block - Make from 1/4" balsa

Midwest Piper J-3

Modifications to Original

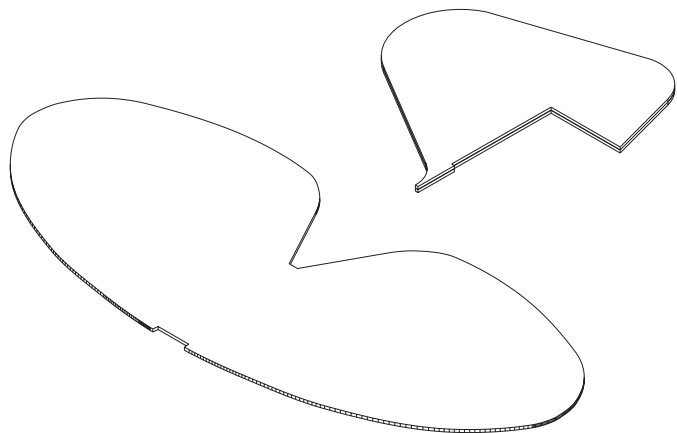

Note: The stab and elevators are one piece as opposed to multiple pieces as shown on the plan.

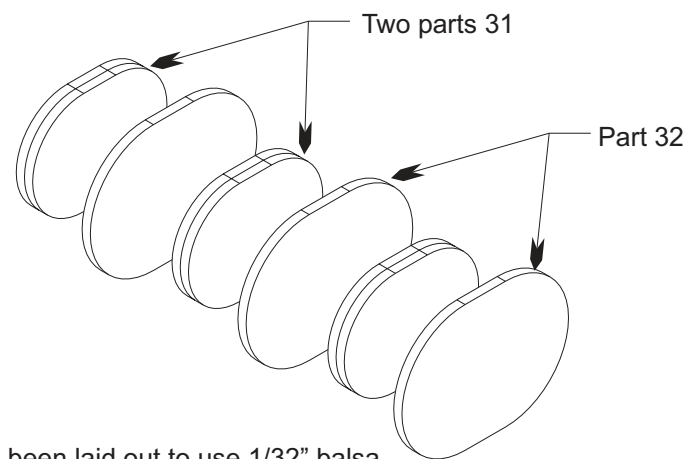

The dummy engine has been laid out to use 1/32" balsa laminations as opposed to 1/16" laminations as shown on the kit plan. Use two parts 31 as shown to separate the three parts 32. Make two assemblies.

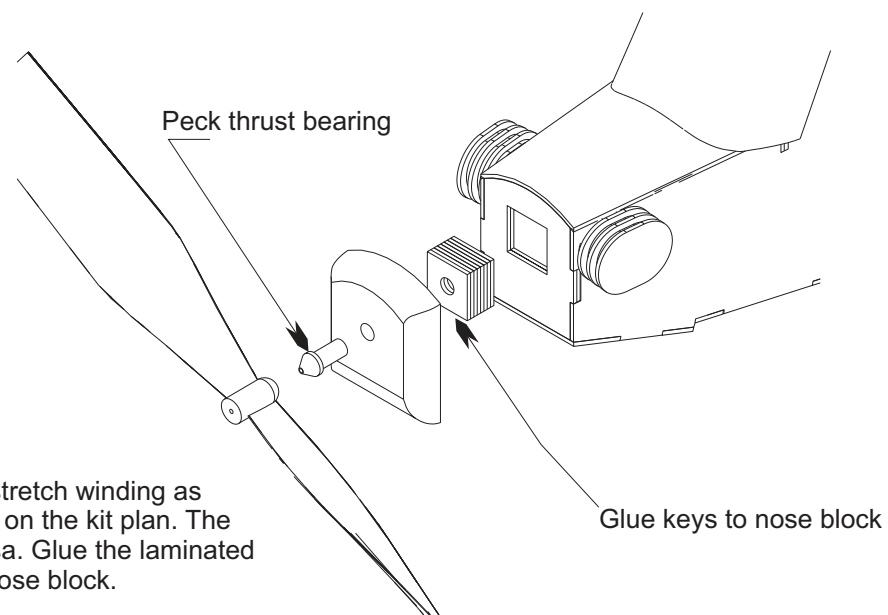

The nose block is removable for stretch winding as opposed to the fixed block shown on the kit plan. The nose block is made from 1/4" balsa. Glue the laminated key block to the rear face of the nose block.

Midwest Piper J-3



Free Builder
MIDWEST PRODUCTS CO.

PIPER CUB J-3

RUBBER BAND POWERED SPORT FLYER



22 Wingspan
Formed wire landing gear
Propeller, wheels
and Decals included

PRINTED & DIE CUT WOOD

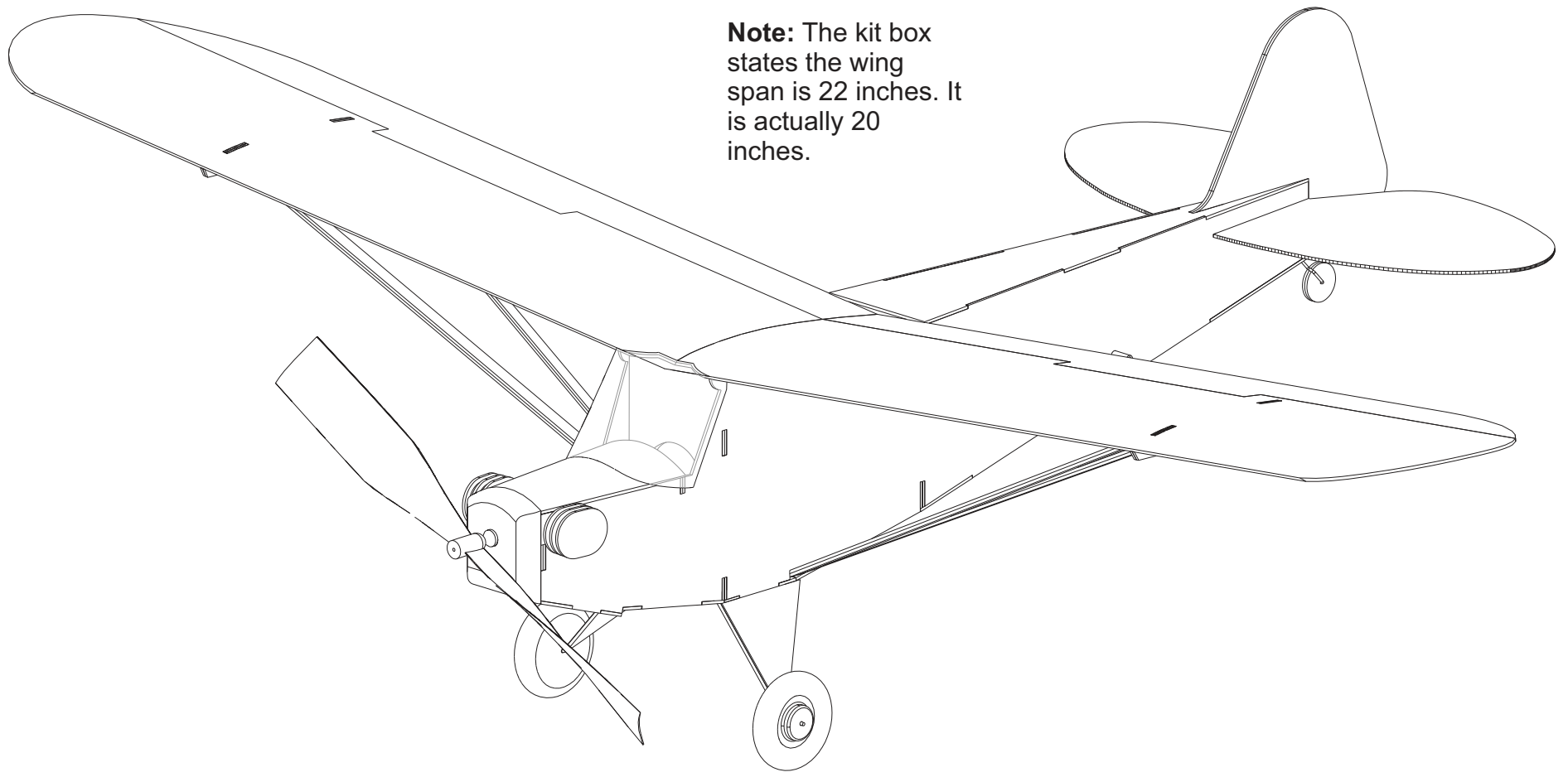

Note: The kit box states the wing span is 22 inches. It is actually 20 inches.