

ORIGAMI E2

An electric powered model made from sheet foam based on the configuration of a paper glider.

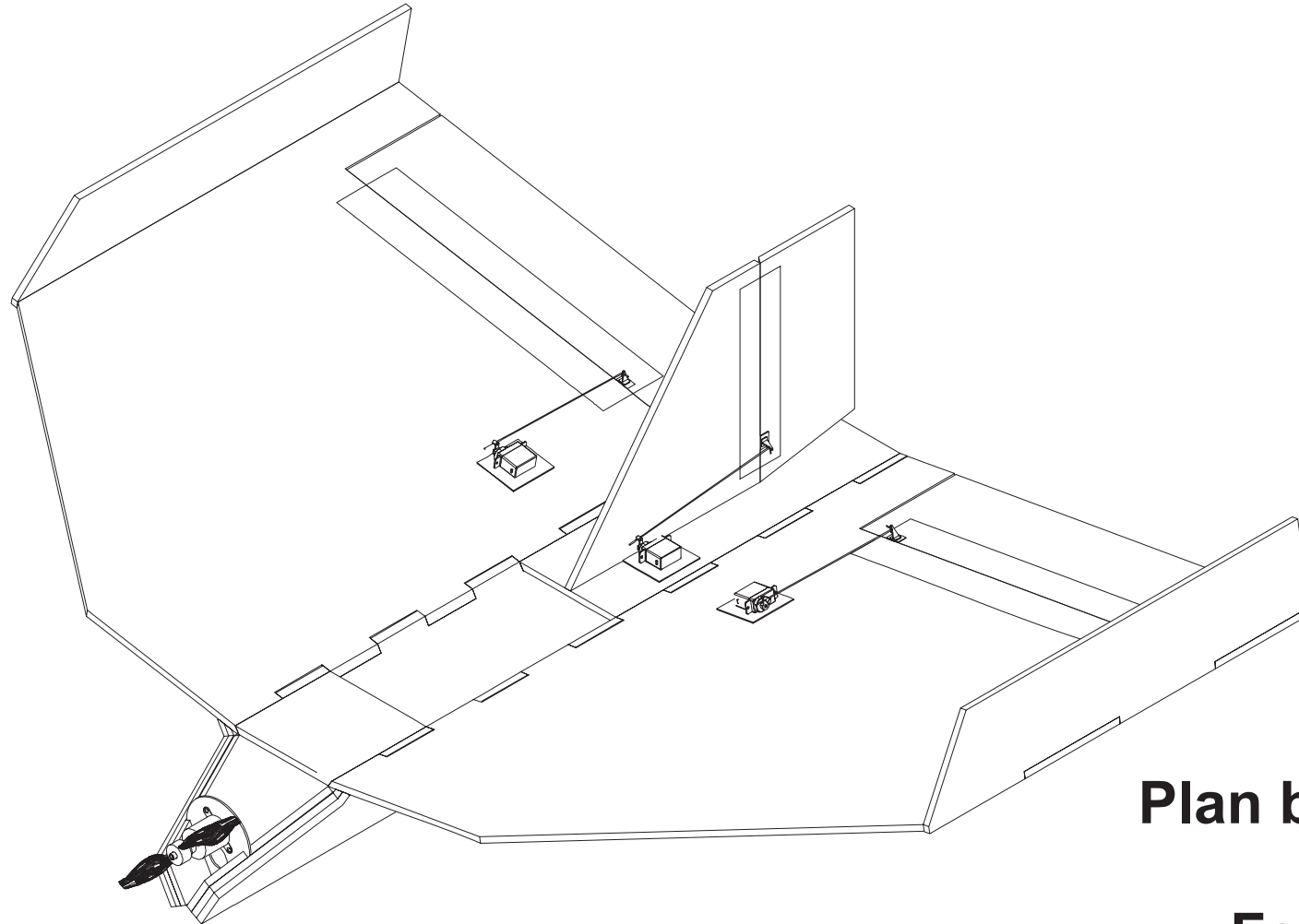

Concept and
general
arrangement by

Jack Pignolo

Plan by Paul Bradley

February 2010

ORIGAMI E2

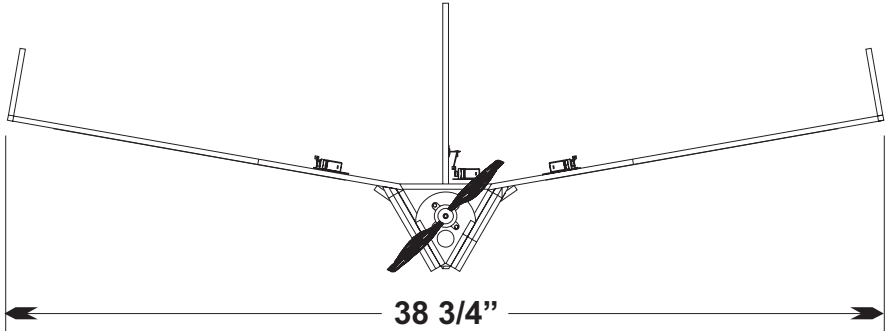

Concept and
general
arrangement by

Jack Pignolo

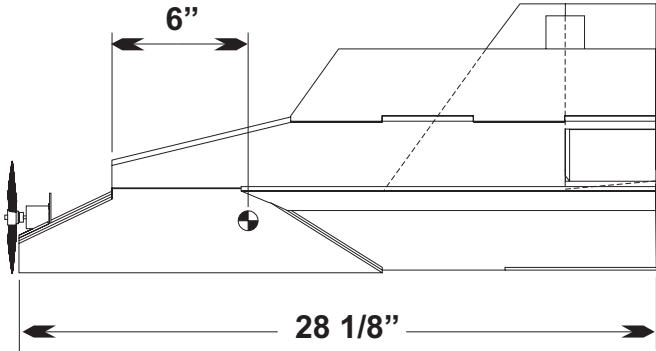
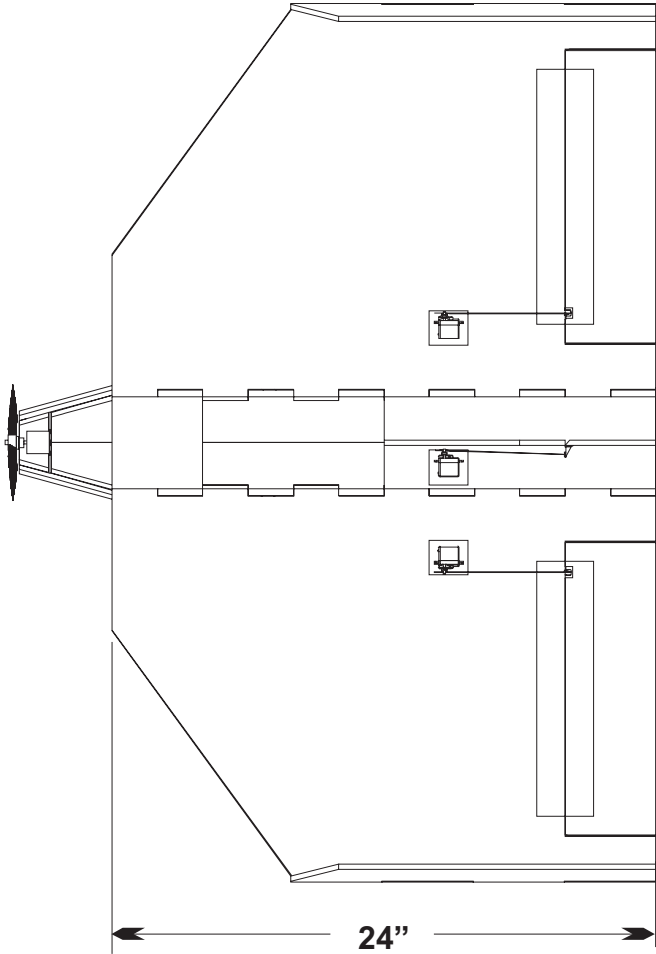

Origami E2 Assembly Guide

The model presented in this package is fairly simple sheet foam low wing loading model based on the outlines of a folded paper glider. The concept and general design concept are those of Jack Pignolo. The original model was built from fan fold foam that is about 1/4" thick. The plan presented in this package calls for 6mm foam sheet stock. Either can be used.

The prototype model used a low cost brushless outrunner motor from Hobby City turning a 8x4.5 electric prop and a three cell 1320 mah battery pack. You can use any motor that will produce at least 60 watts of power.

The materials needed to build a model from this plan are listed below:

1. 6mm foam sheets - Five 13" x 1 meter sheets are suggested
2. 1/32" plywood
3. 1/8" plywood
4. Spray adhesive
5. White glue or similar product
6. Motor - A brushless outrunner motor is suggested that can produce at least 60 watts of power
7. Prop - sized to produce at least 60 watts of power from your motor.
8. Prop adapter for the motor
9. At least a three channel radio system. A micro receiver is recommended.
10. Micro servos - three
11. Electronic Speed Control (ESC) with a Battery Eliminator Circuit (BEC) capable of at least 10 amps
12. Micro control horns - three

One good source for 6mm foam sheets is RC Foam. You will find them at <http://www.rcfoam.com>.

A model built from this plan package has a wing span of 38 3/4 inches with an overall length of 28 inches. The total flying surface area is 825 square inches. The total flying weight will depend on the materials used, the selected motor, and battery pack. The total flying weight should be in the range of 15 ounces.

General Assembly Notes

1. Printing and assembling the part templates.

Many of the part templates had to be printed on individual sheets of paper to make sure all printers could be used to generate the templates. The largest paper size that all printers can handle are sheets 8 1/2" by 14" (Legal size in the U.S.). The pages of this package have been set up to print on that size paper.

For parts that are printed on multiple sheets, sheet alignment marks have been included. Place one sheet on top of another using the alignment marks. Tape the sheets together on each side. Cut the templates from the assembled sheets. An illustration is provided below:

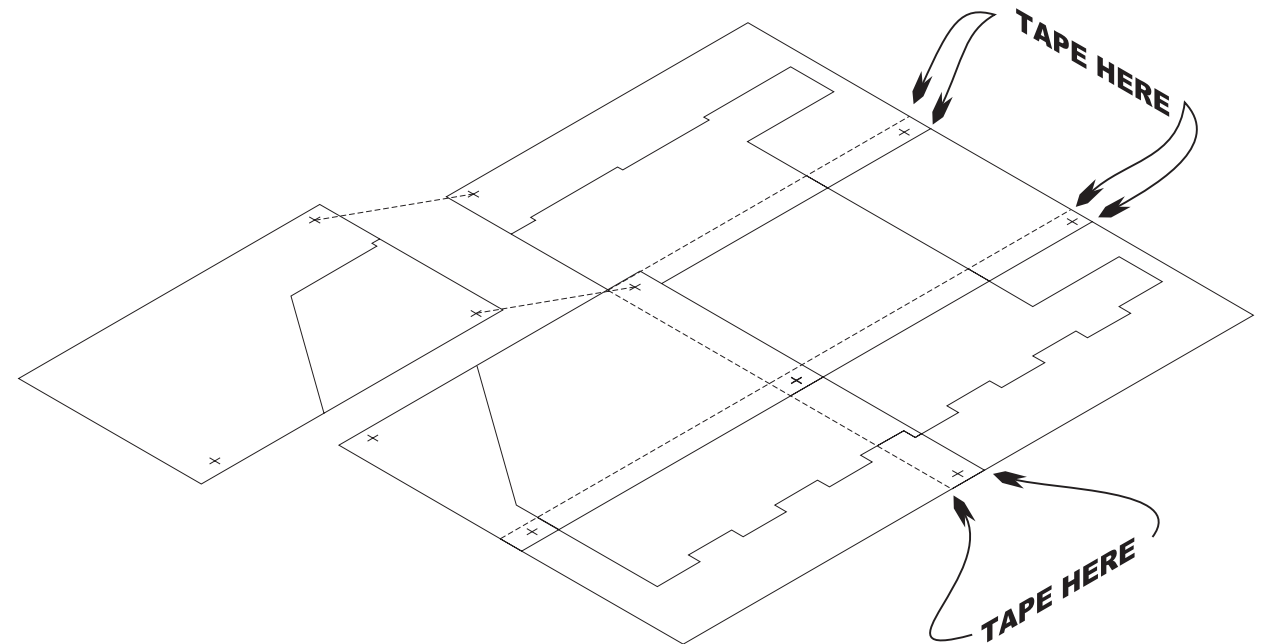

2. Attaching the templates to the construction materials.

A very good way to attach the paper templates to the construction material so they can be easily removed (and reused in some cases) is to use a spray adhesive. Please note that spray contact cements should not be used as they form permanent bonds. There are several low cost spray adhesives available. Two that were used for the prototype are Duro All Purpose Spray Adhesive and 3M General Purpose 45 Spray Adhesive. These products are available at home improvement centers, office supply stores, and general department stores.

To form a temporary bond, spray a light coat of the adhesive on the paper template. Let it dry for a half minute or so. The template can then be stuck to the construction material. After the part is cut the template can be easily removed without damage to the template or the cut part.

Some parts need several copies made. The printed paper template can simply be reapplied to the construction material without needing additional spray adhesive. If a given template gets damaged before all the parts have been cut, just print out the page or pages that contain the template and make up a new one.

2. Getting started.

A guide has been provided showing how the individual printed part sheets fit together. Tape the individual sheets together according to the guide. Once the sheets have been taped together the individual parts can be cut from them and applied to the foam sheets. Cut each part from the foam sheets noting where multiple copies of individual parts are required.

The detailed assembly steps are detailed in the pages that follow.

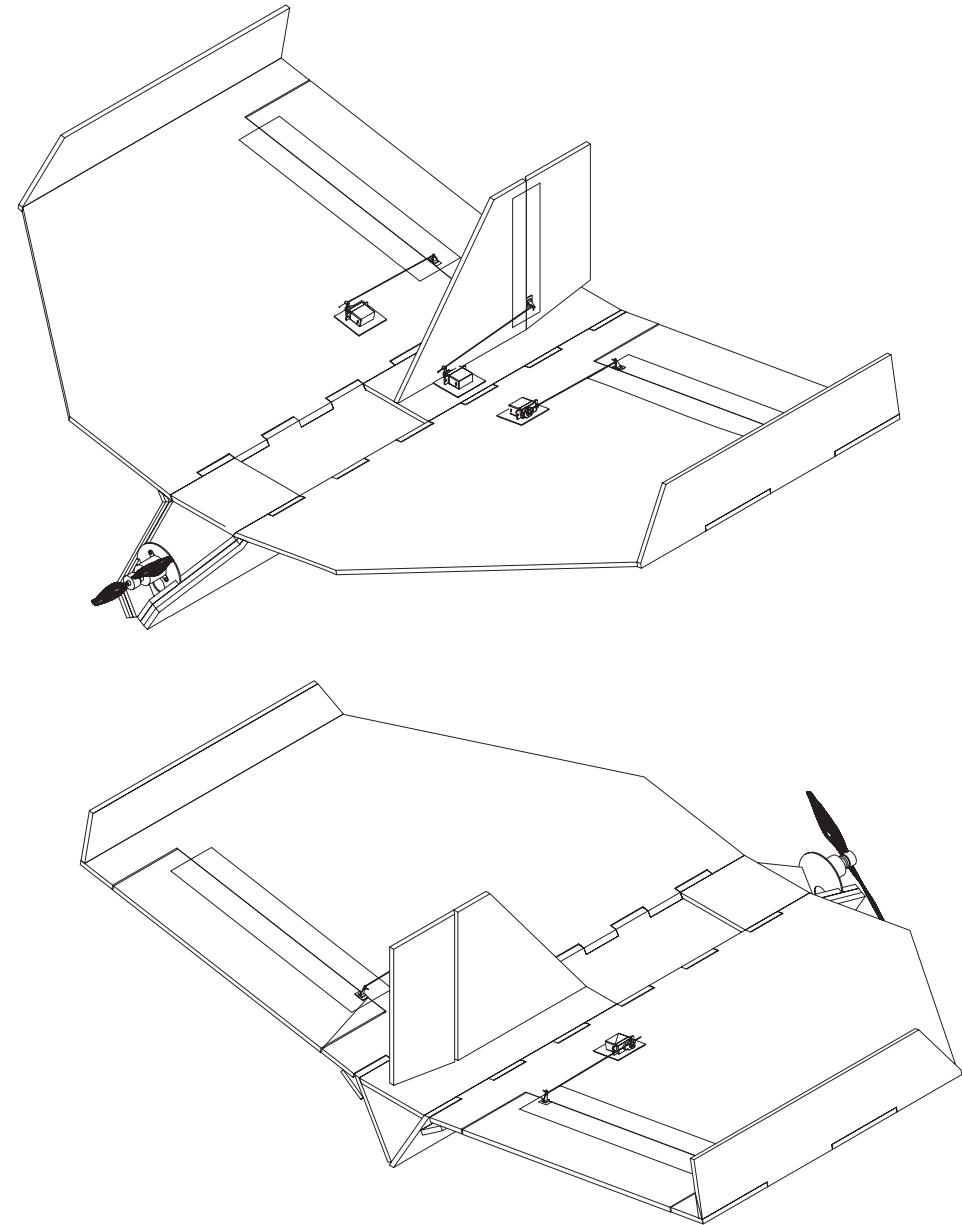

Assembly Steps

1.

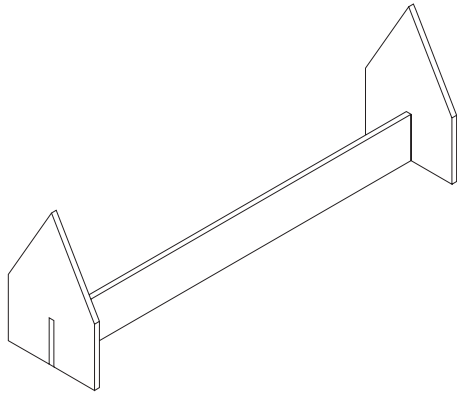

Assemble the fuselage assembly jig components as shown.

2.

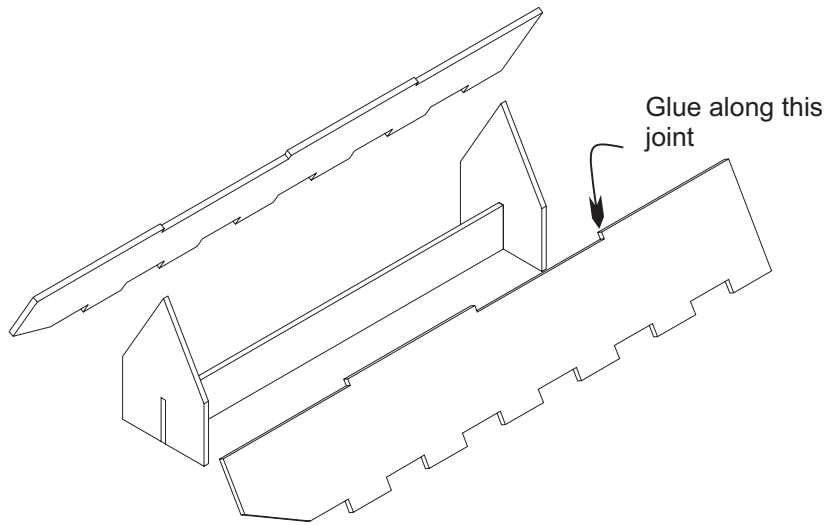

Assemble the two fuselage sides as shown upside down over the assembly jig. **Do not glue the sides to the jig.** Glue the sides together at the bottom joint.

3.

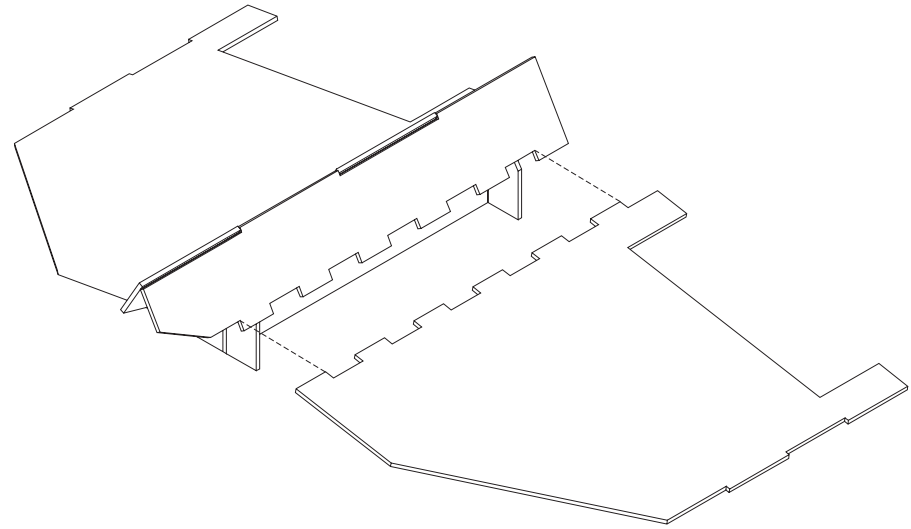

With the fuselage resting on the assembly jig, glue each wing panel in place. The tips of each panel rest on your building surface. The dihedral will be automatically set to the correct amount.

4.

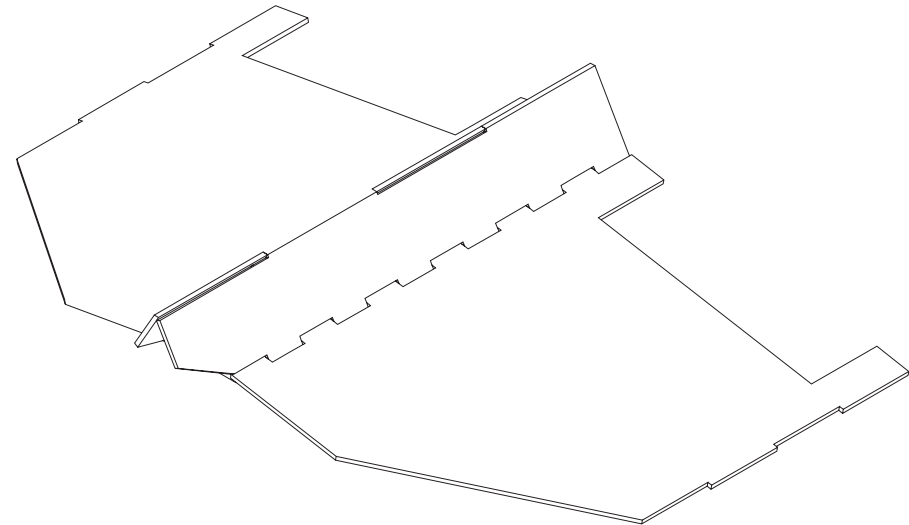

Trim the bottom of the fuselage to be flat. Leave everything on the jig for now.

5.

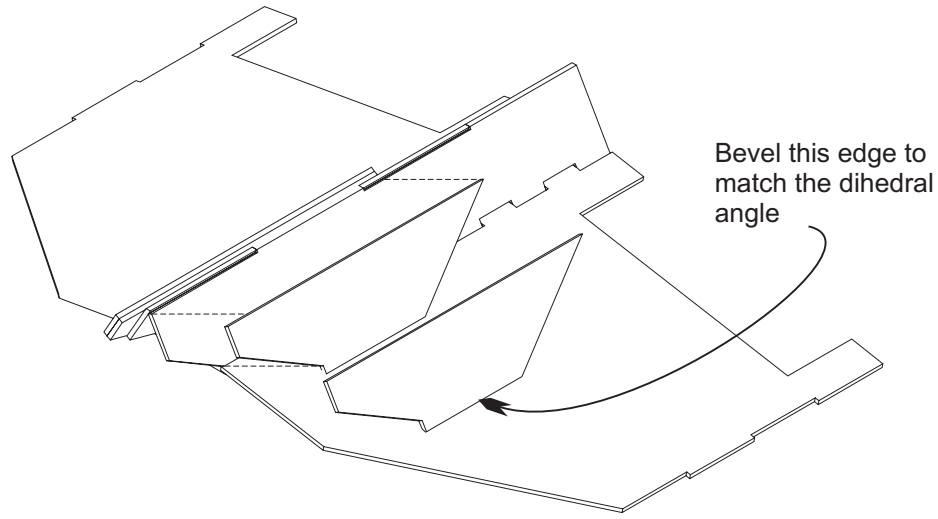

Glue 2 fuselage doublers to each side of the fuselage. Use the sloped front edge as a location guide. The doublers will extend forward of the fuselage sides. Bevel each doubler to fit the wing dihedral angle.

6.

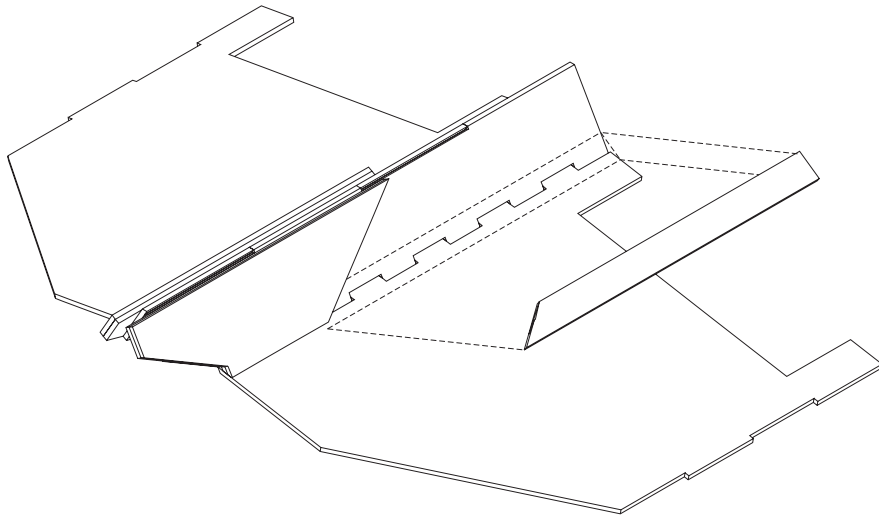

Glue a dihedral brace to each side of the fuselage and corresponding wing panel. The pieces are set at an angle so the edges touch the fuselage side and wing panel with a space between the brace and the fuselage/wing joint. The edges do not need to be beveled.

7.

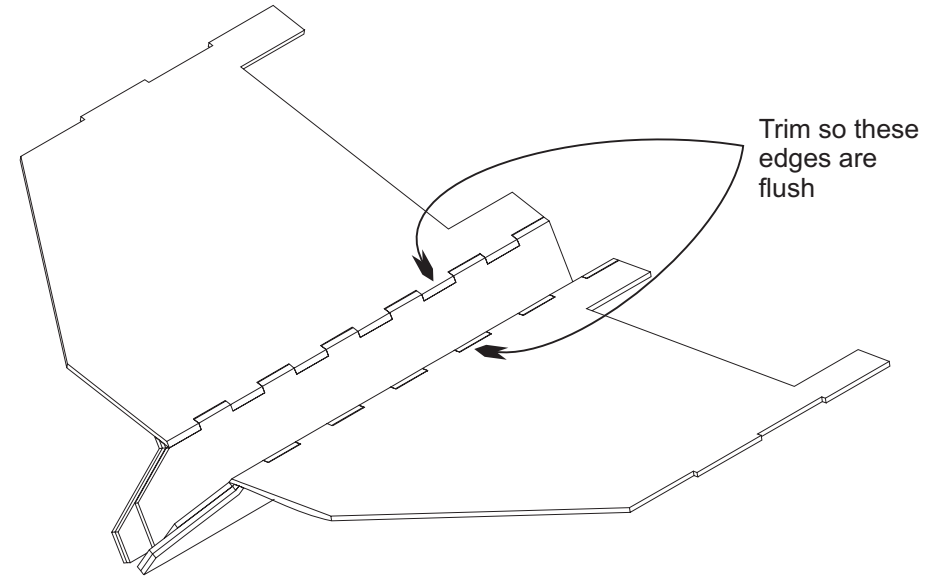

Remove the model from the assembly jig. Trim the wing to fuselage joints so the edges are flush.

8.

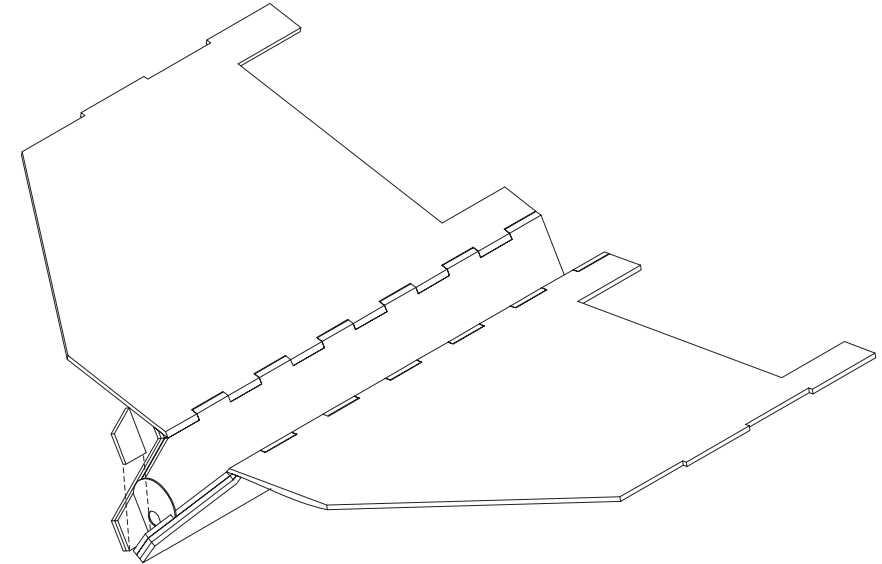

Glue the 1/8" plywood motor mount to the front of the fuselage sides and the inside faces of the doublers. Also glue the forward fuselage side pieces in place in front of the motor mount.

9.

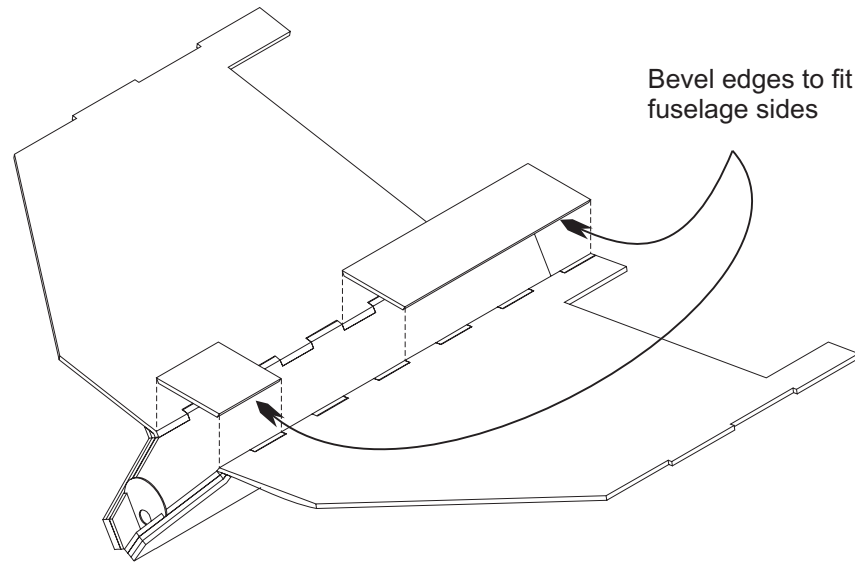

Glue the fuselage top pieces in place as shown. Bevel the edges to fit the fuselage sides.

11.

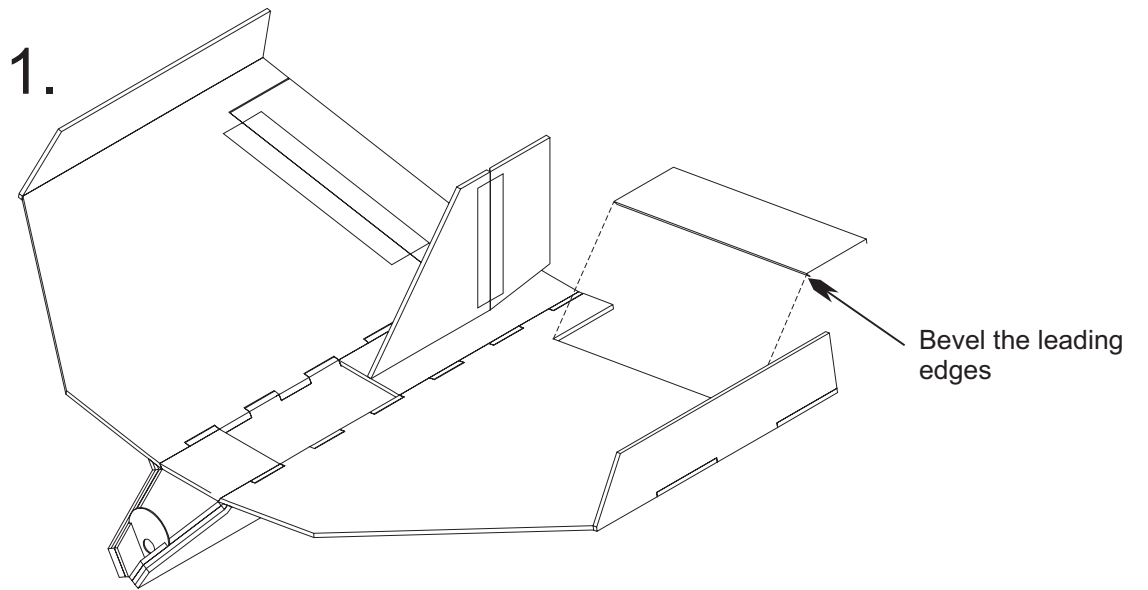

Install the elevators and rudder with hinge tape. Bevel the leading edges before installing.

10.

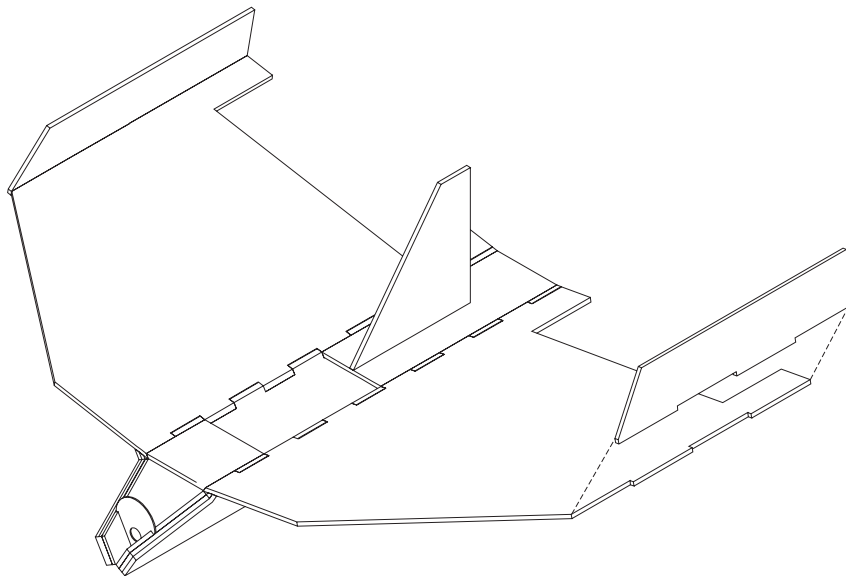

Glue the tip fins and the main fin in place. The tip fins are perpendicular to the wing panels. That makes them look slanted when the model is viewed from the front. The main fin is centered on the rear fuselage top piece and the forward edge is flush with the forward edge of the rear fuselage top piece.

12.

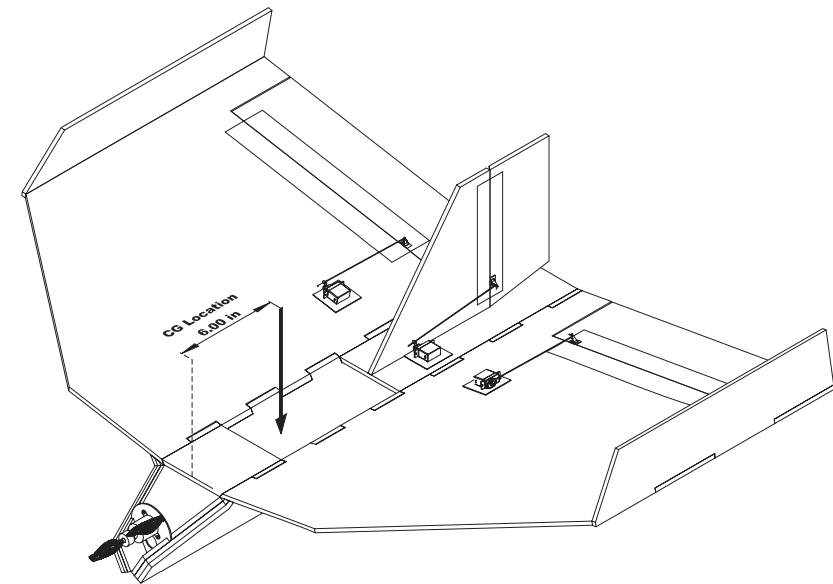

Install the servos, control horns, and pushrods. Use of 1/32" plywood plates under the servos is recommended. Also install the receiver, ESC, and motor to complete the assembly.

Place your chosen battery pack so the Center of Gravity (CG) is located 6 inches back from the wing leading edge.

HOW THE PRINTED SHEETS FIT TOGETHER

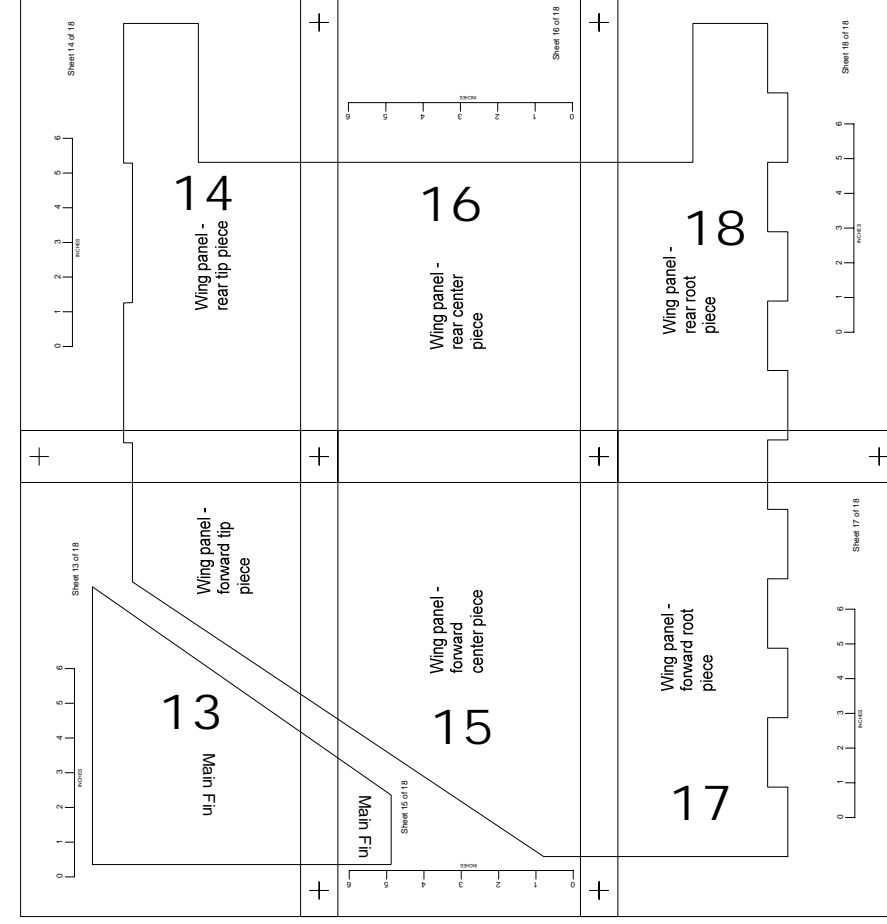
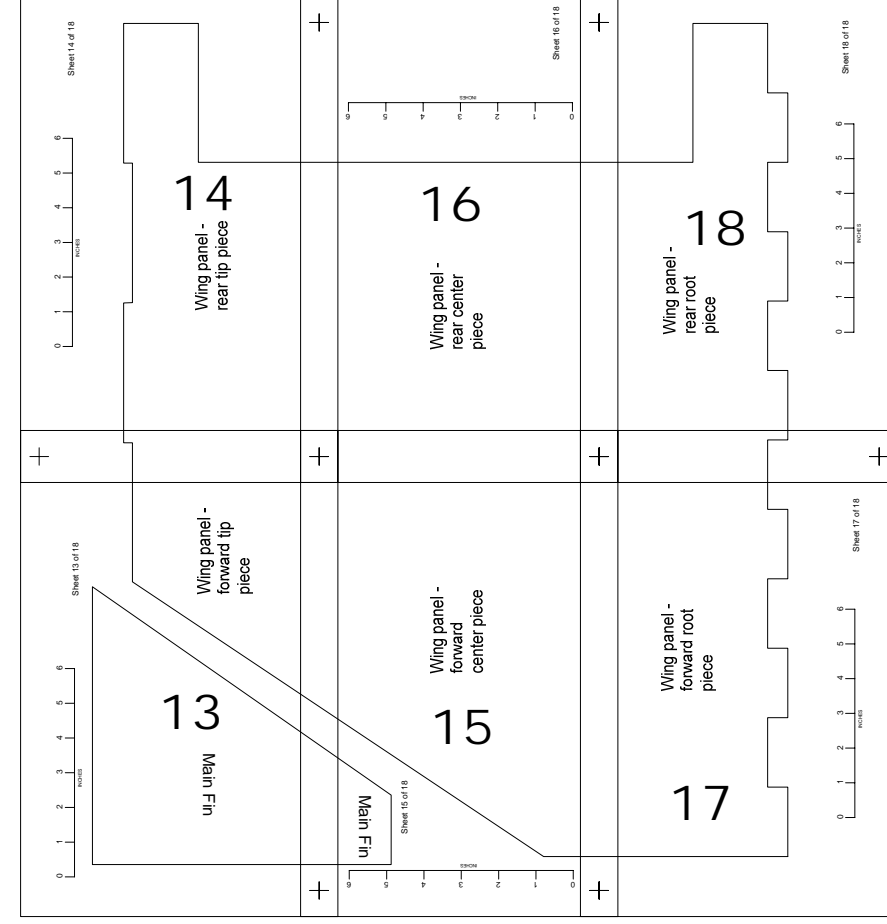
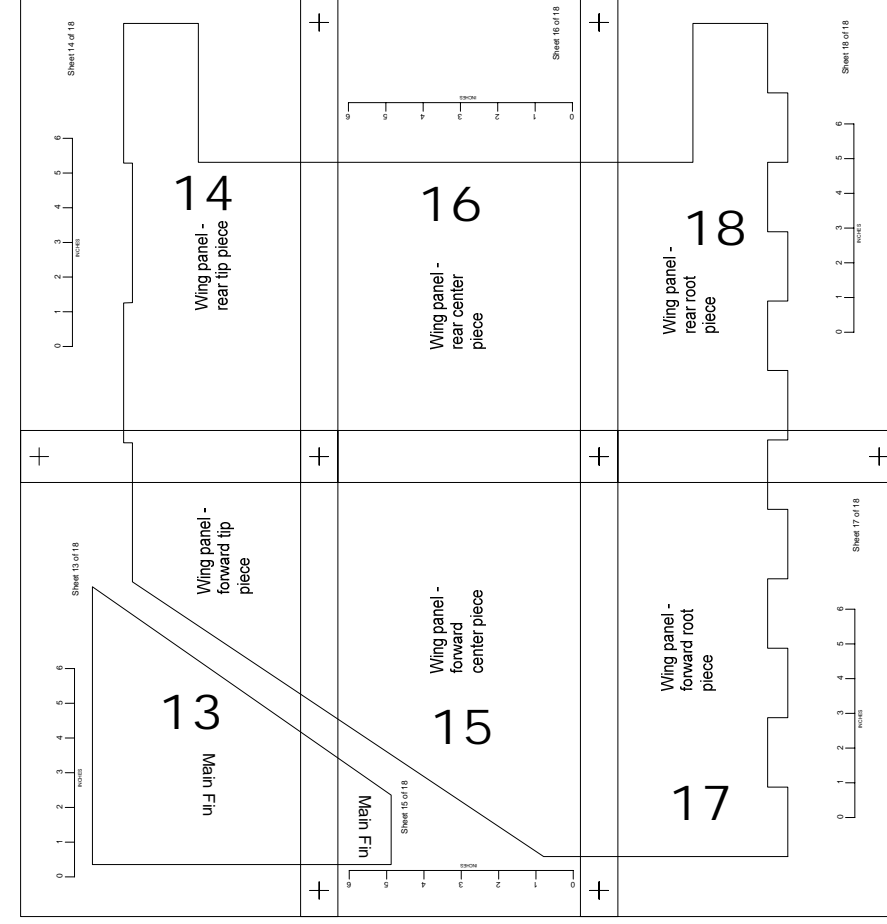
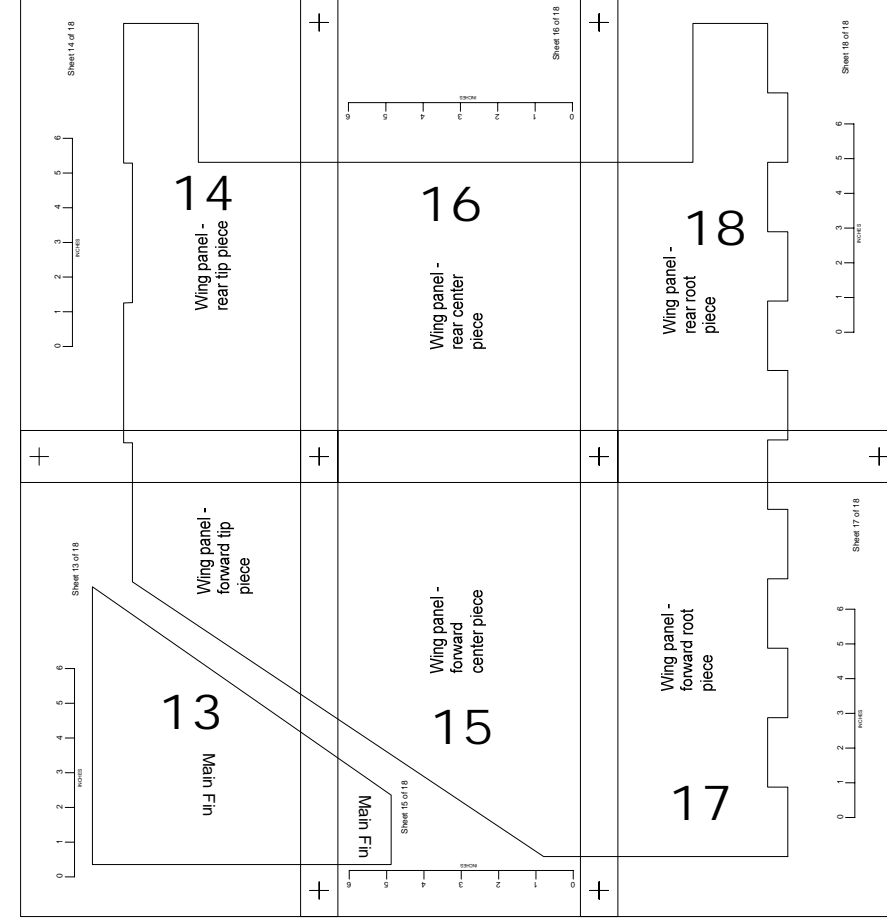
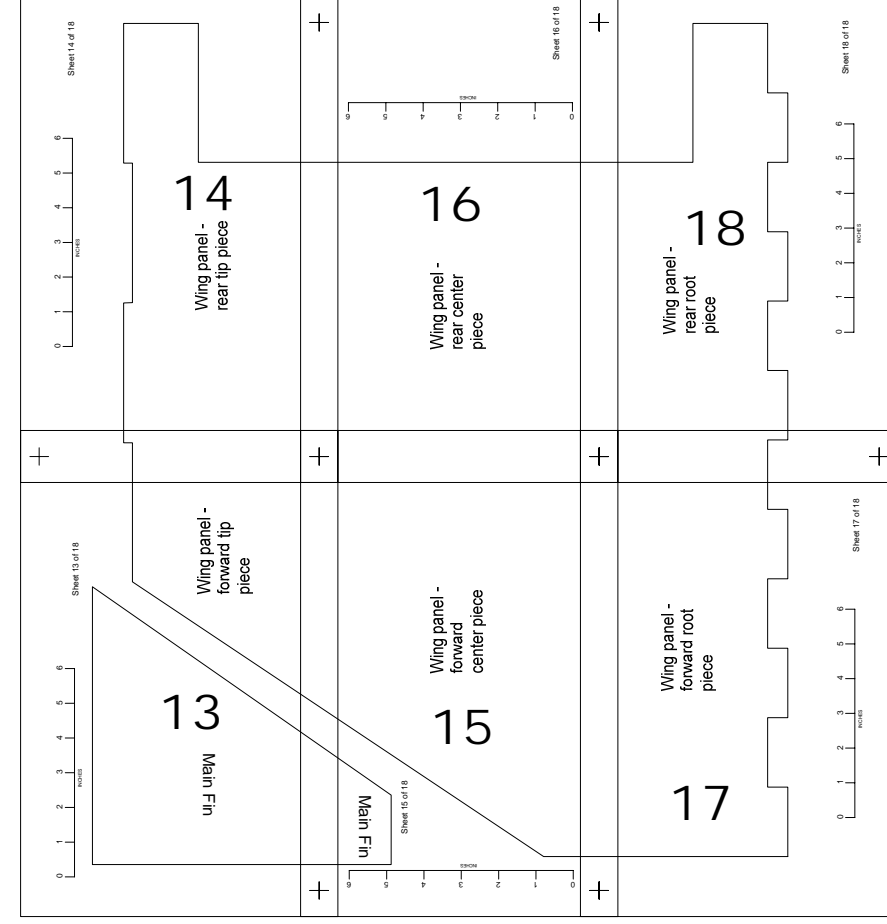
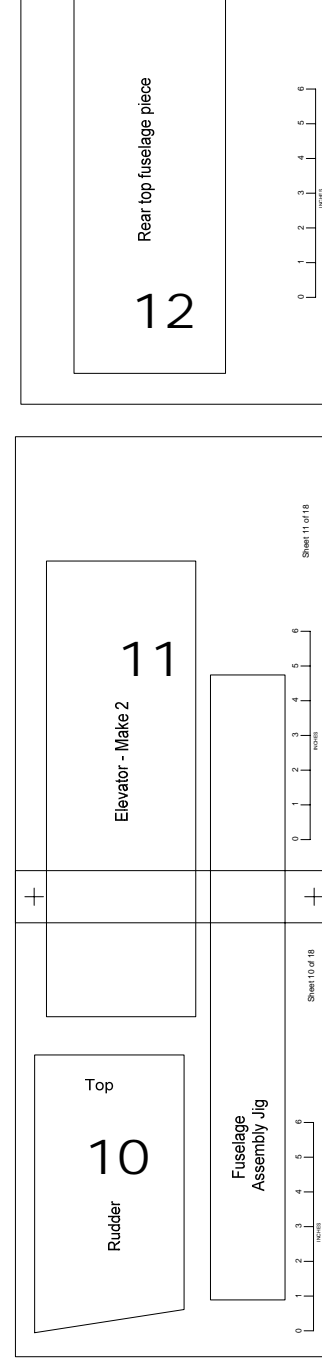
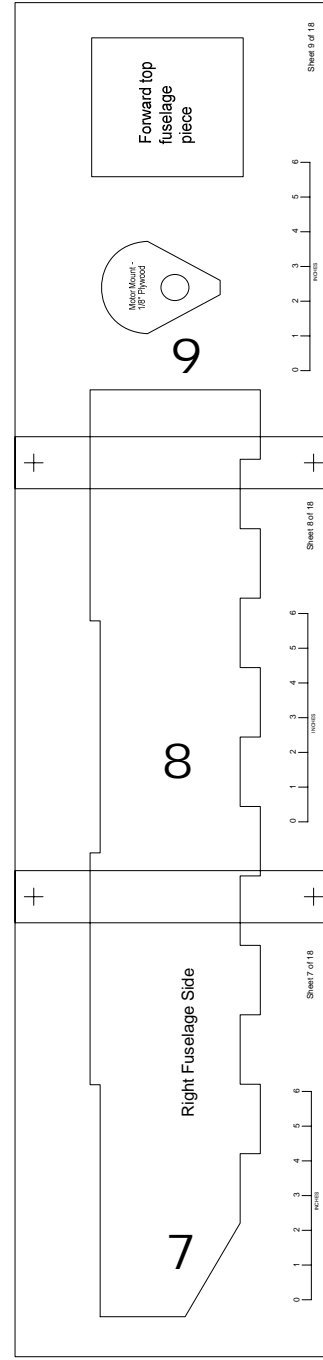
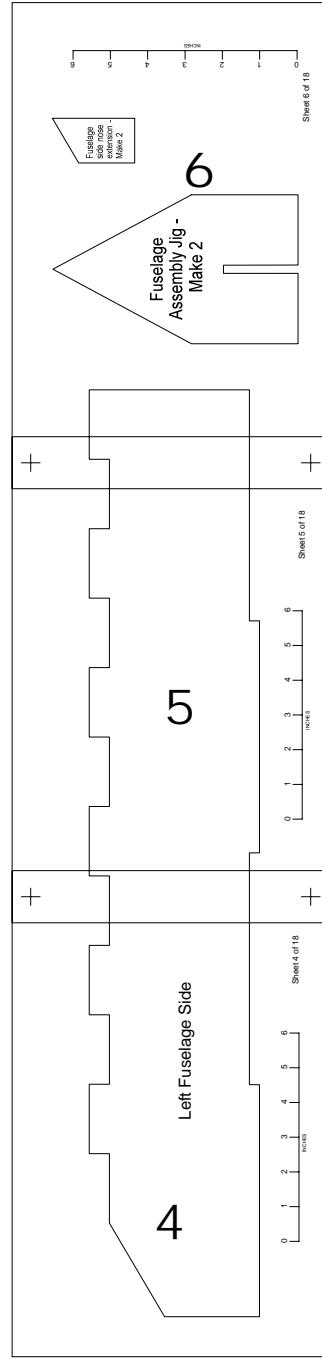
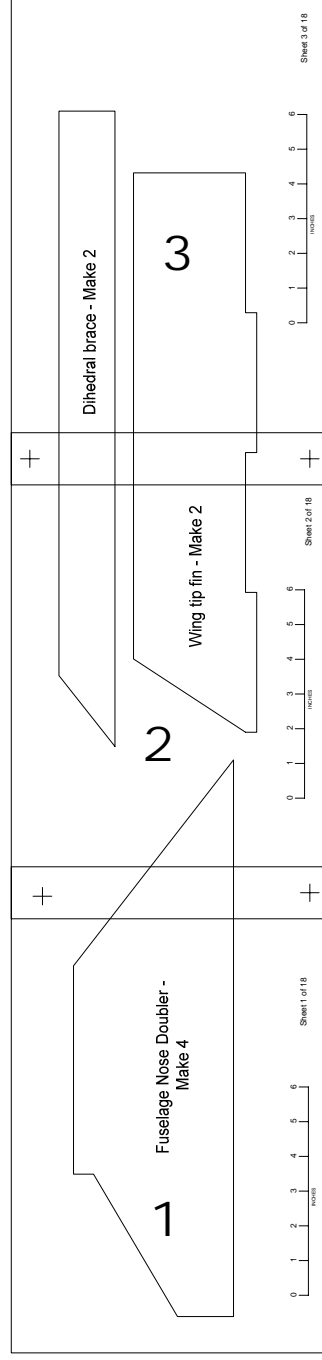

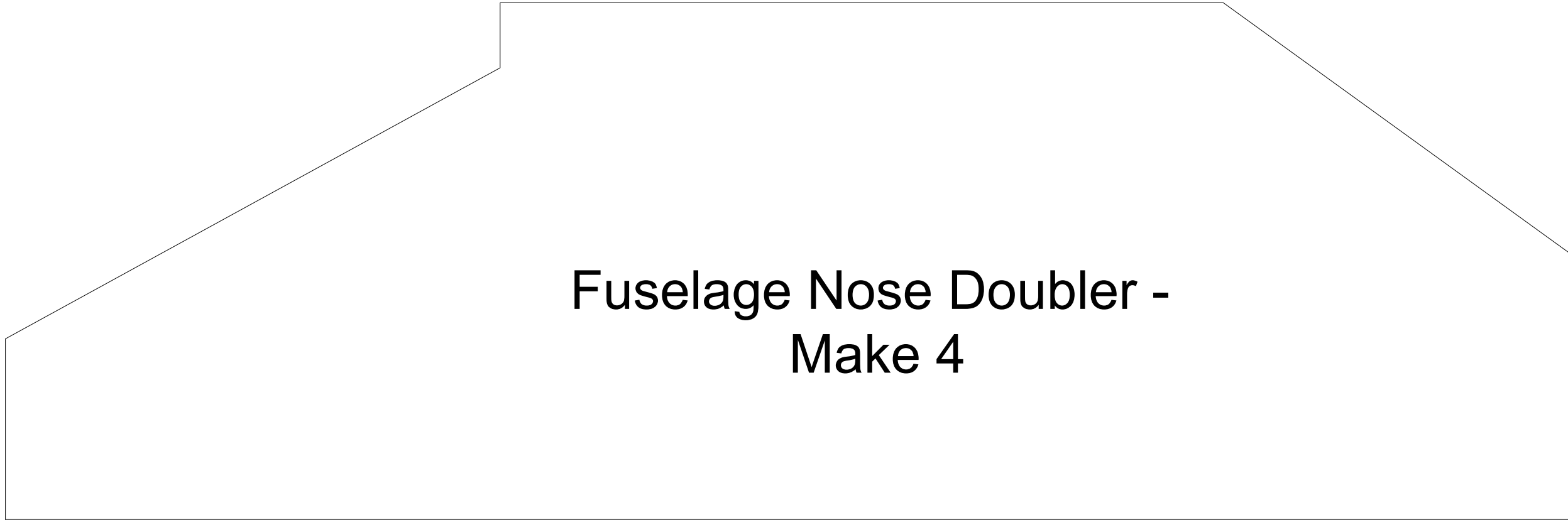
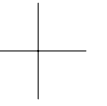

Fuselage Nose Doubler - Make 4

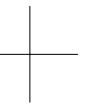
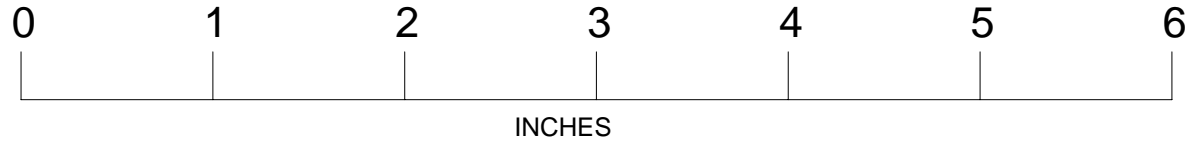

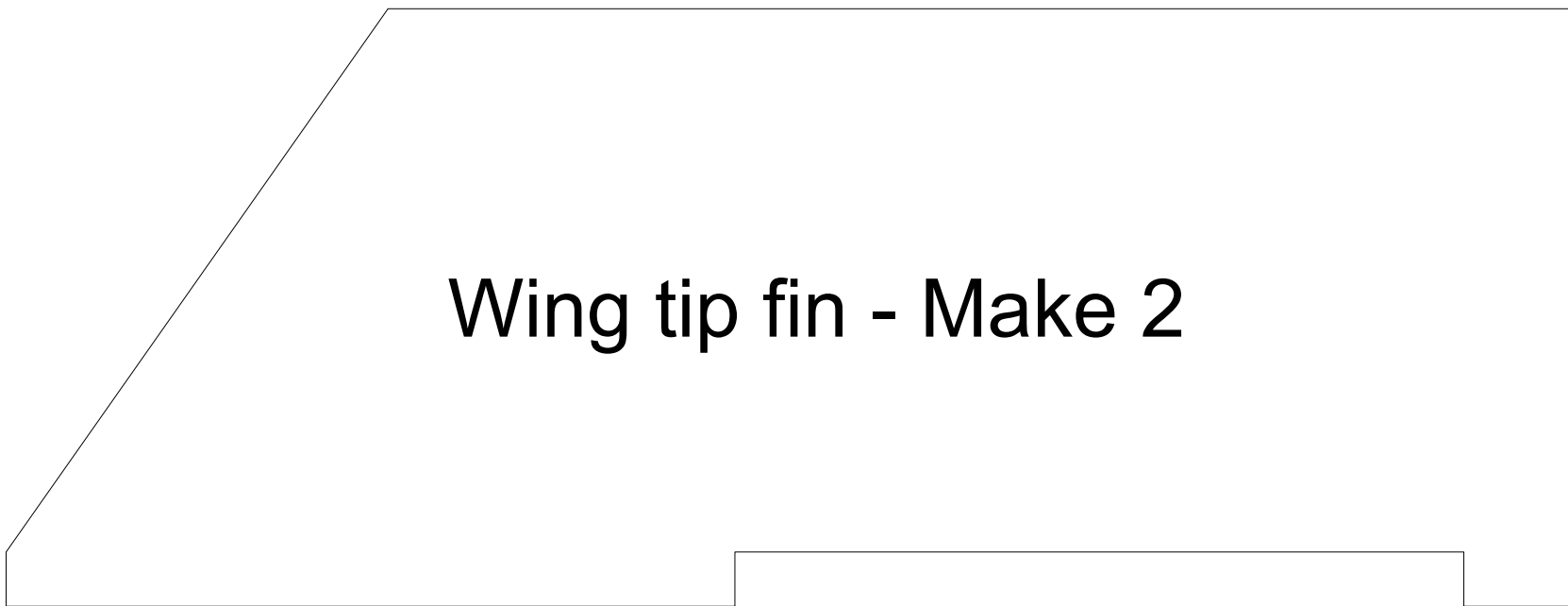
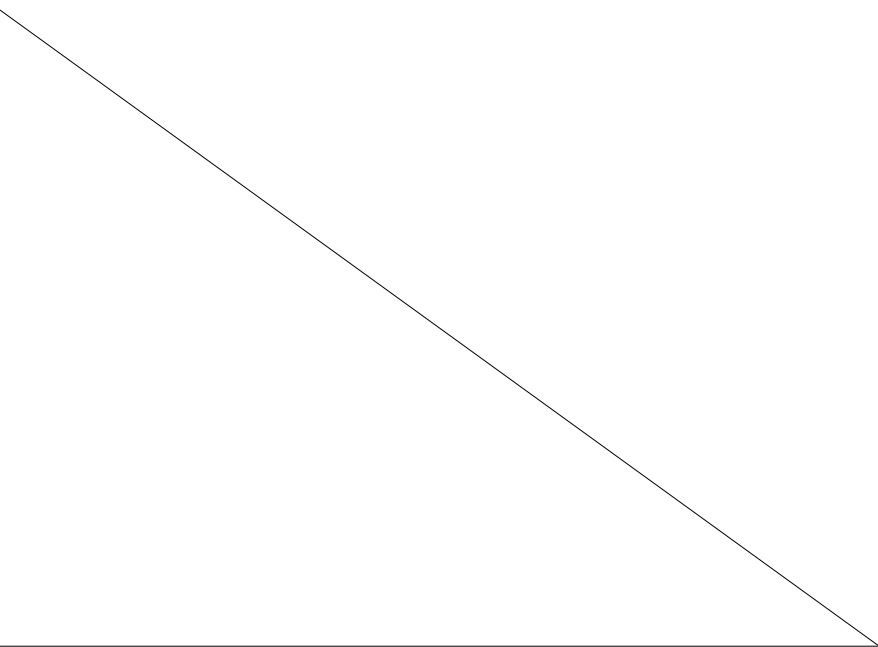
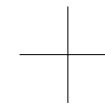
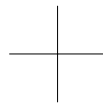

Wing tip fin - Make 2

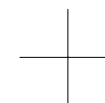
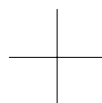
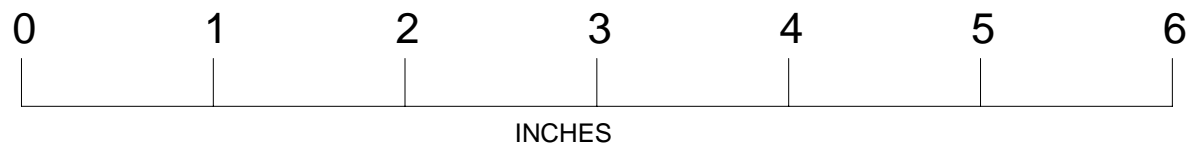



Dihedral brace - Make 2

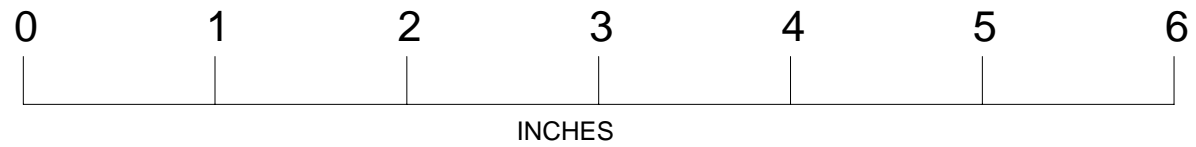
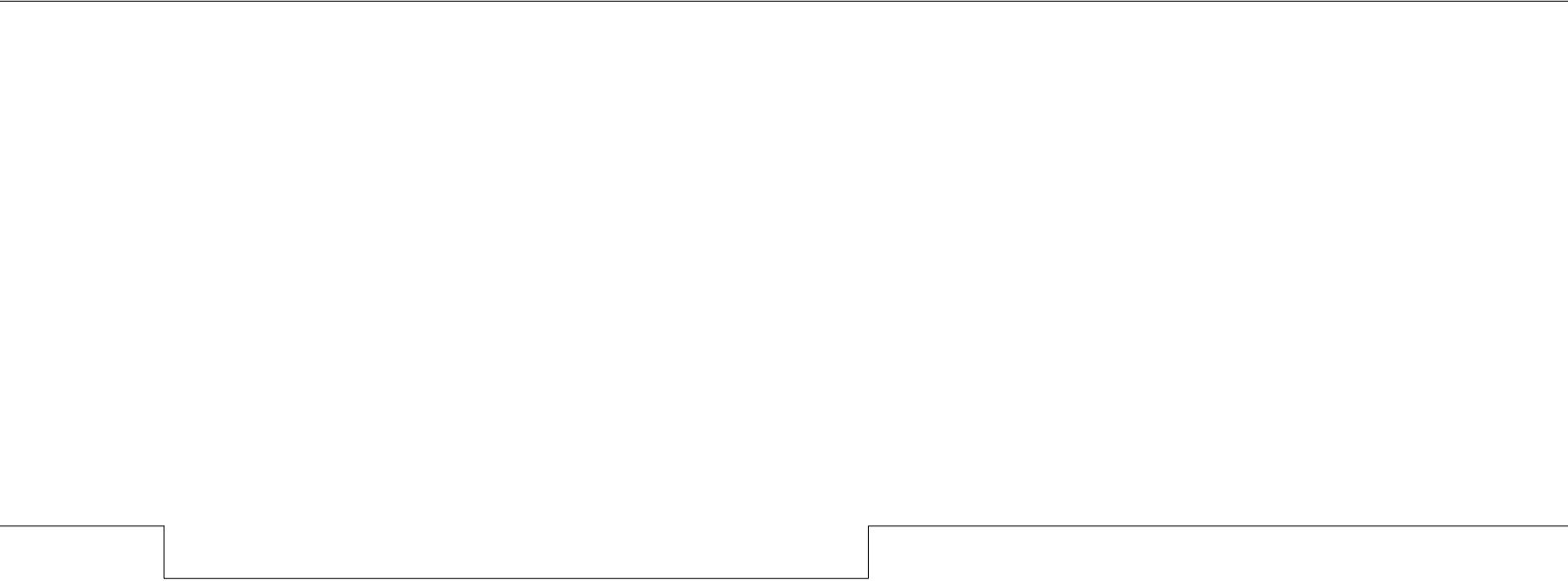

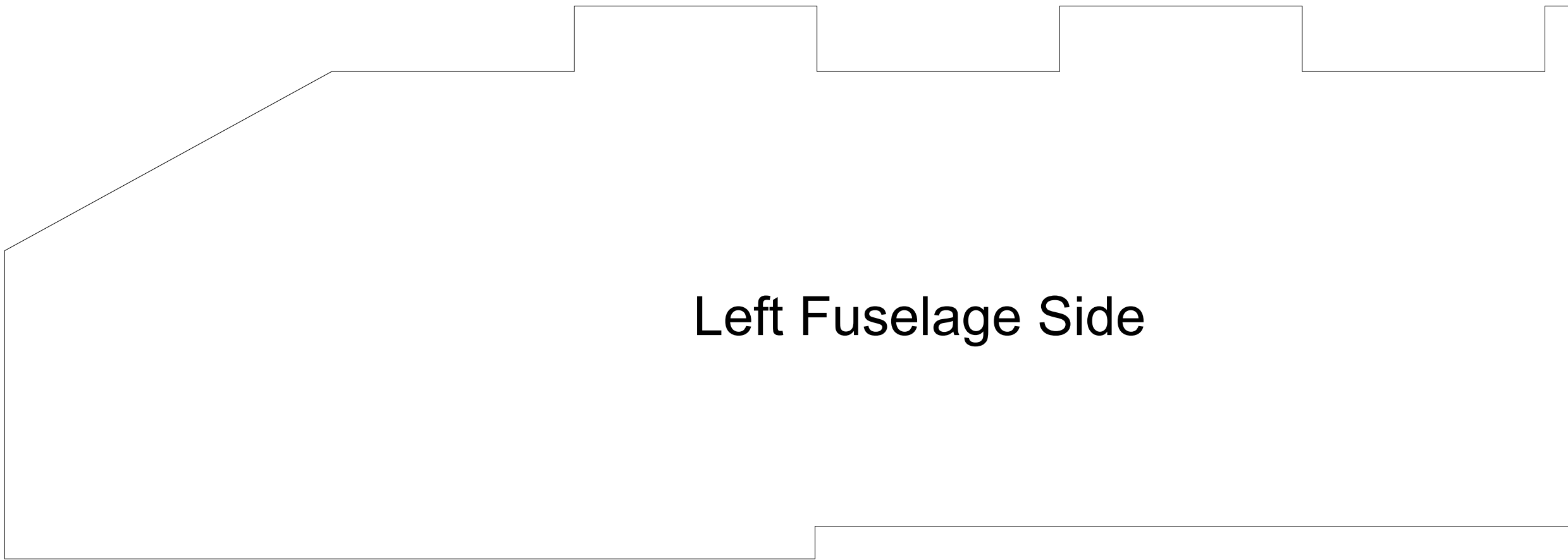
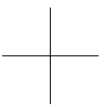

Left Fuselage Side

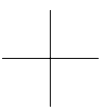
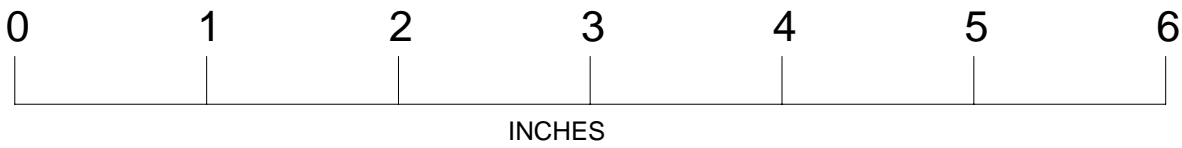

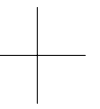
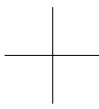
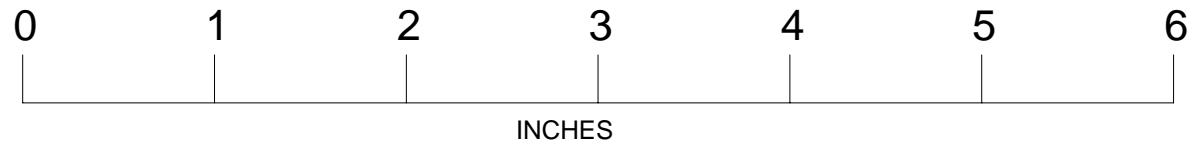
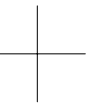
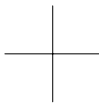

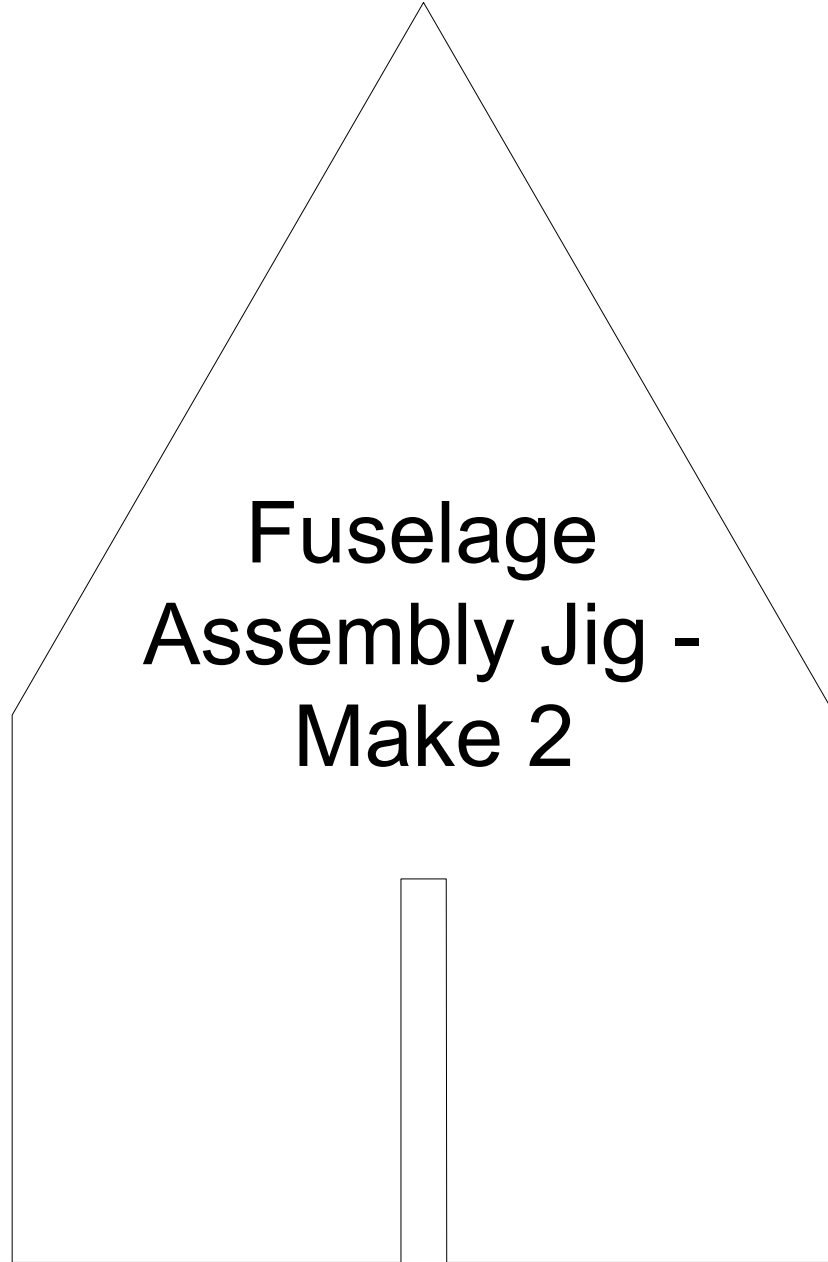
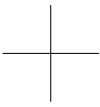

**Fuselage
Assembly Jig -
Make 2**

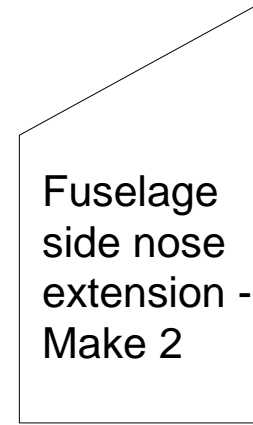

**Fuselage
side nose
extension -
Make 2**

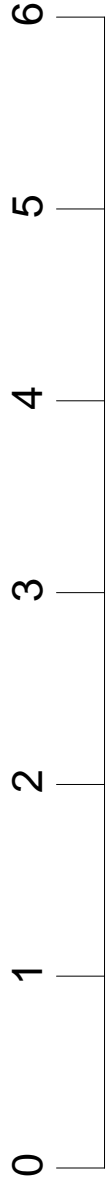

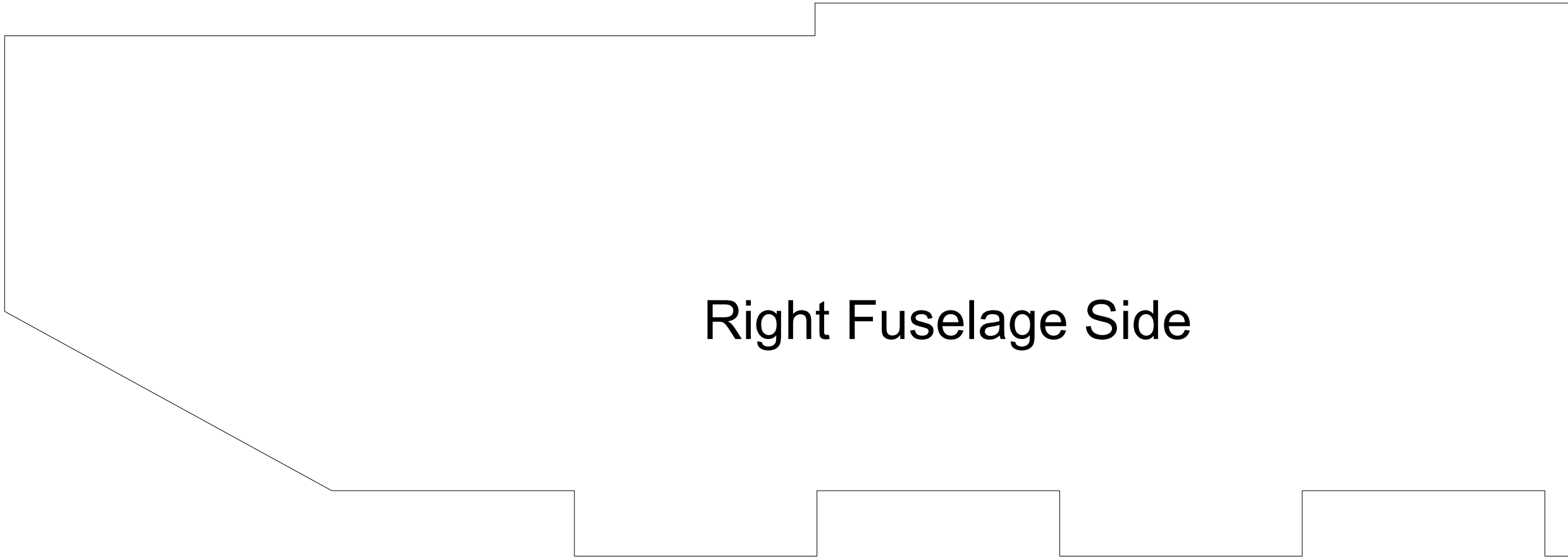
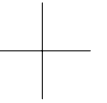

Right Fuselage Side

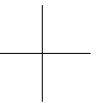
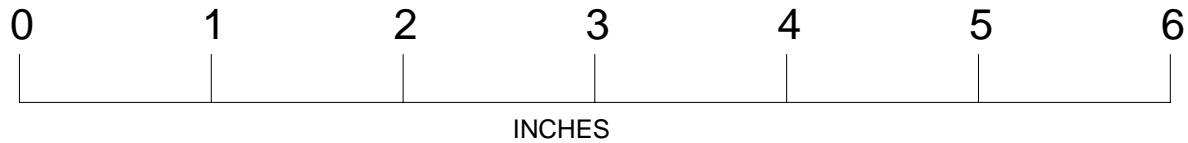

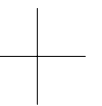
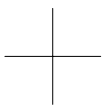
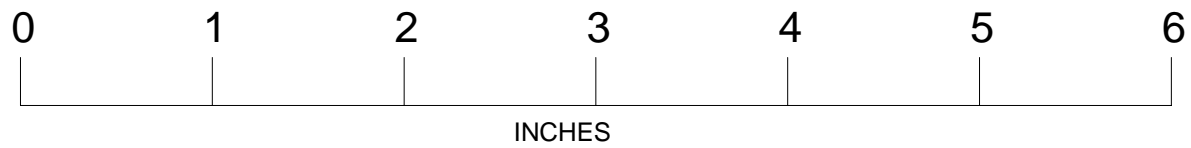
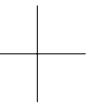
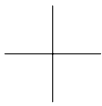

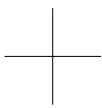
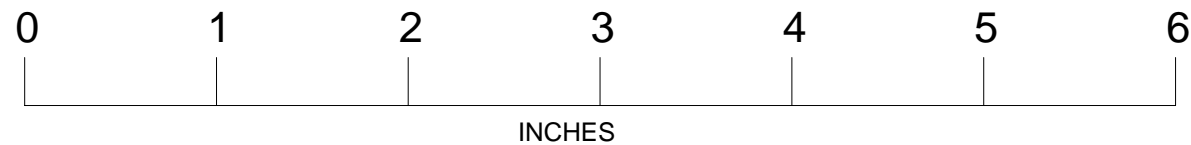
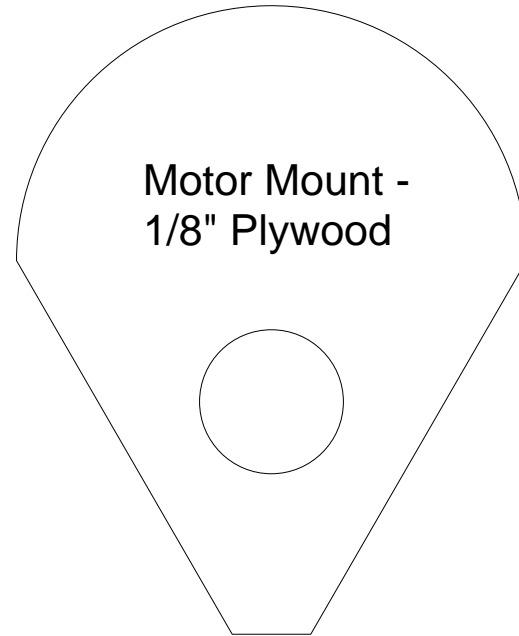

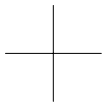
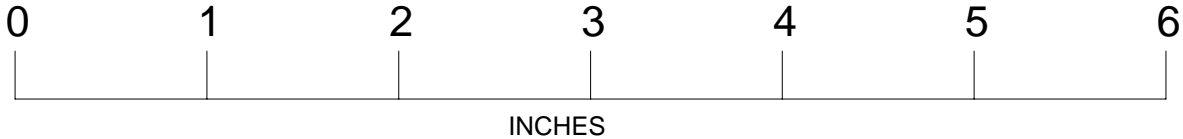
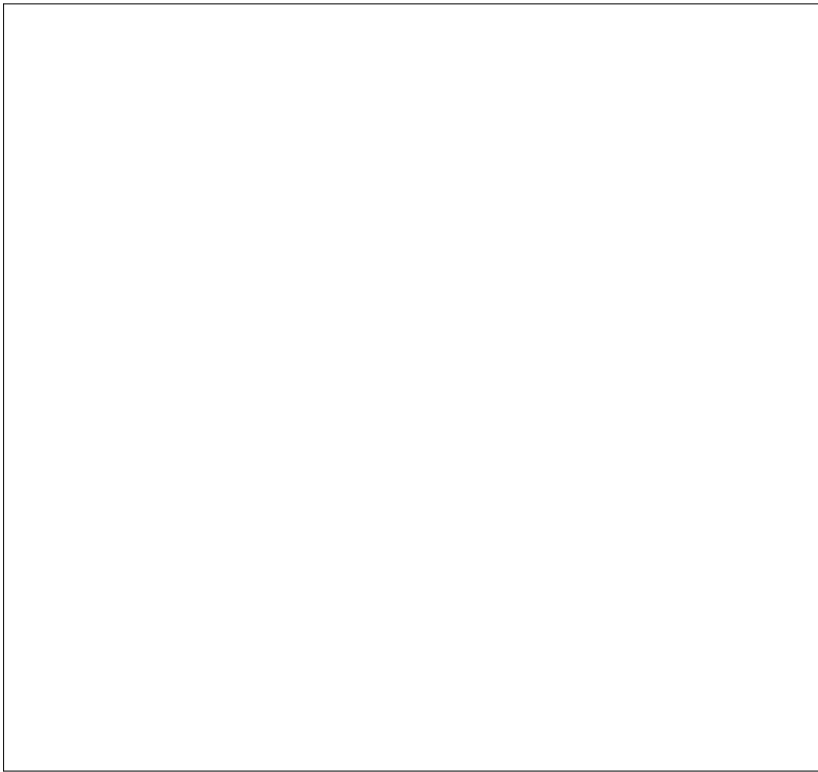
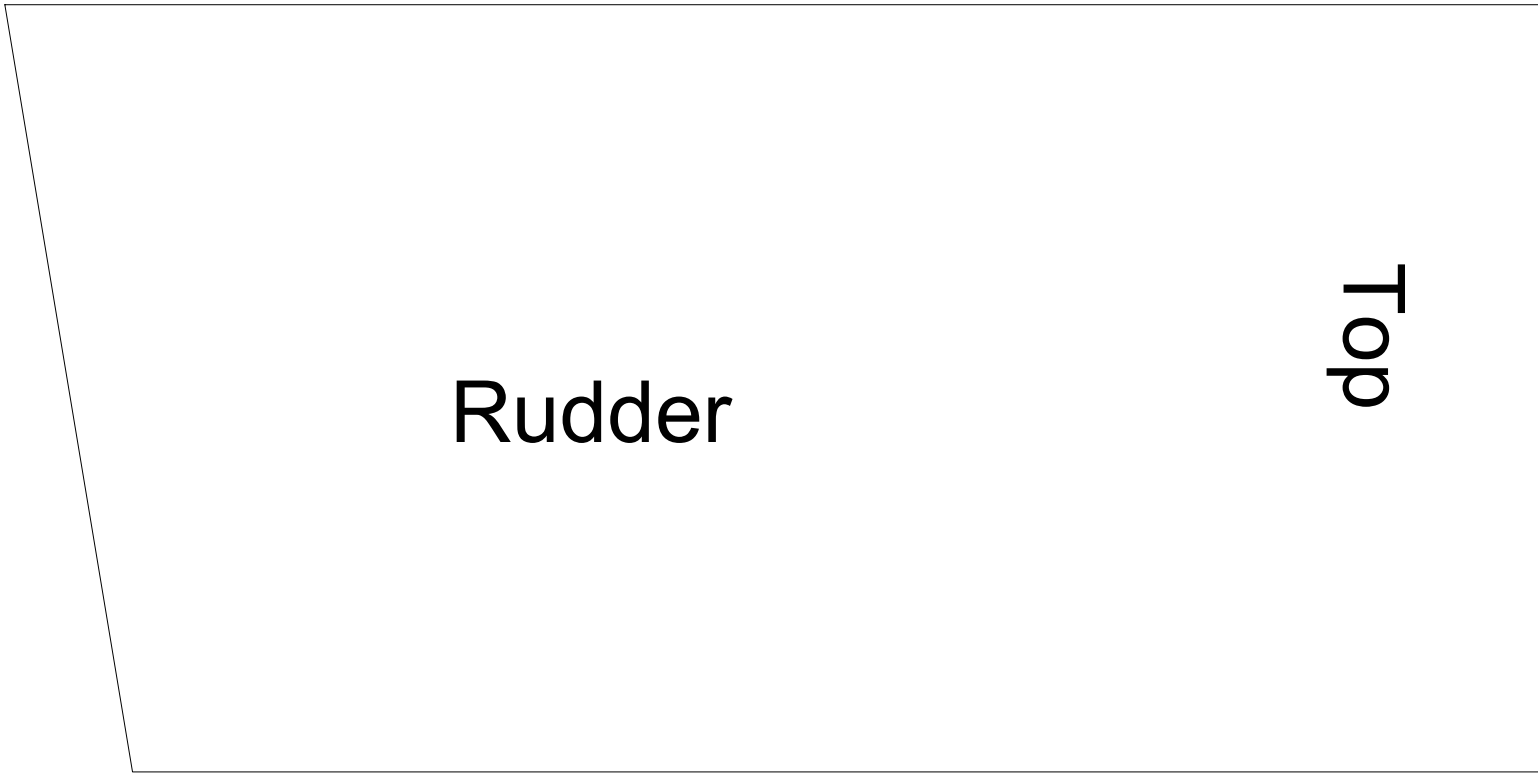



Elevator - Make 2

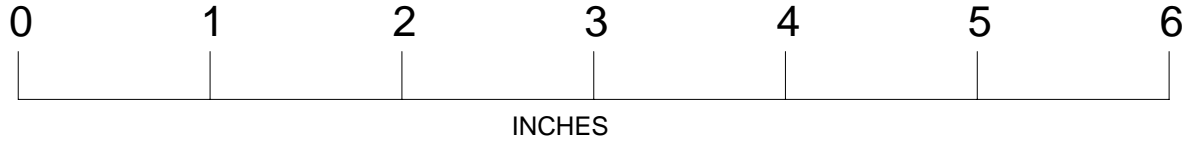
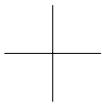

Rear top fuselage piece

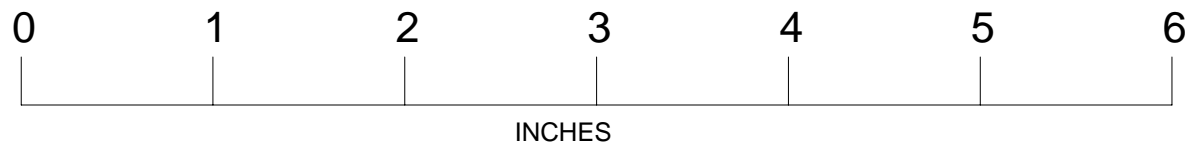

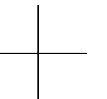
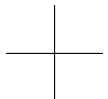
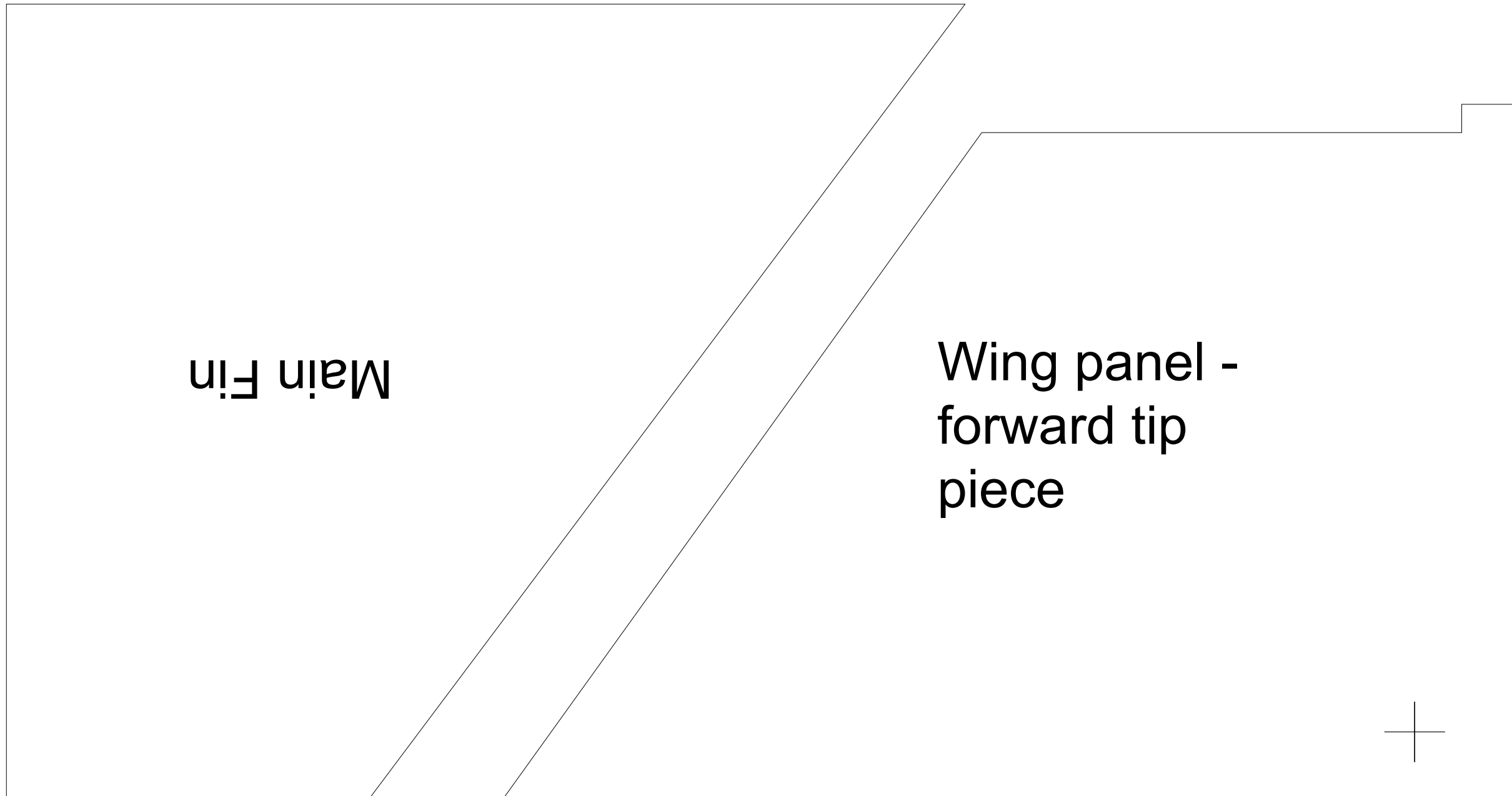
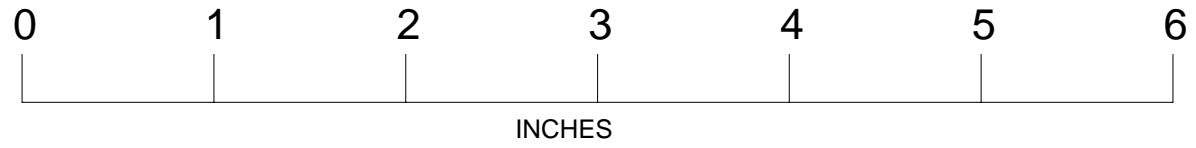
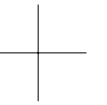

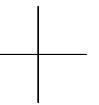
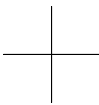
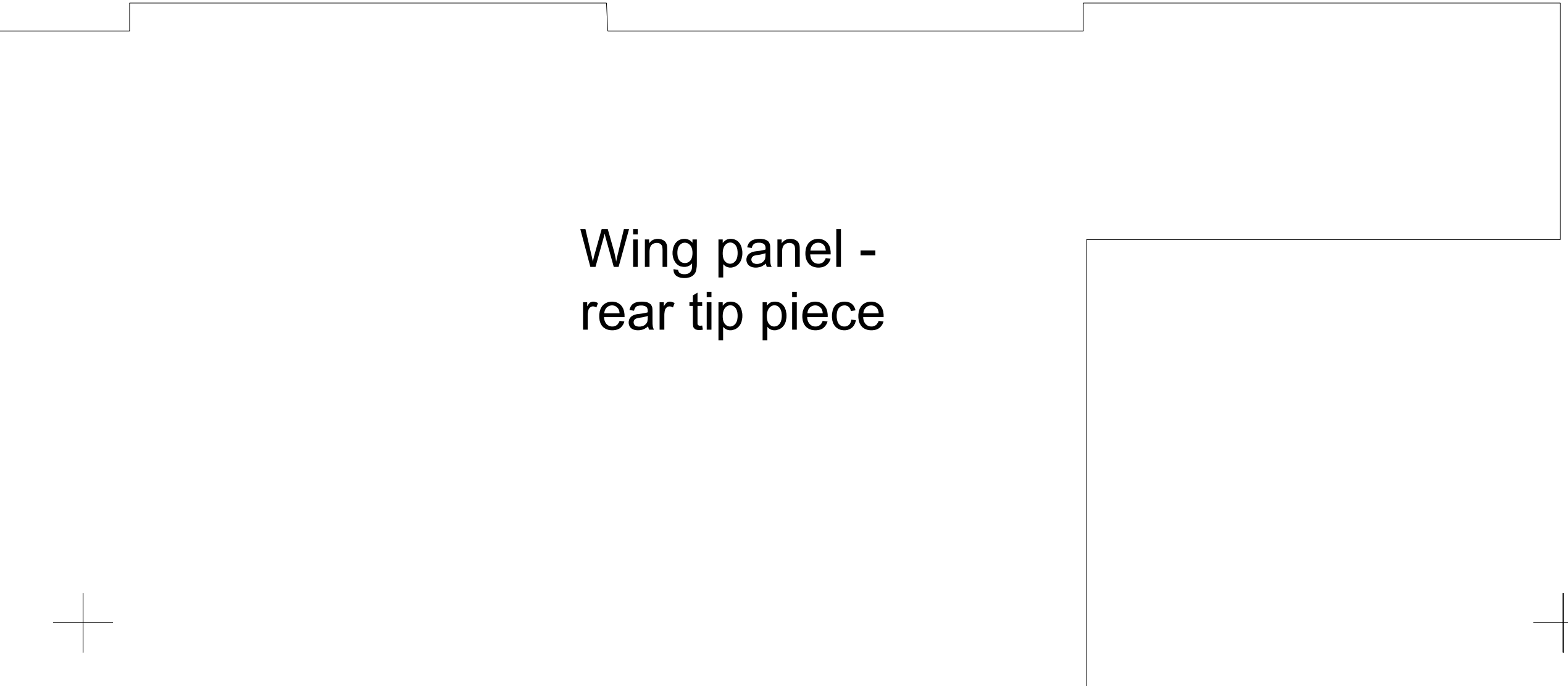
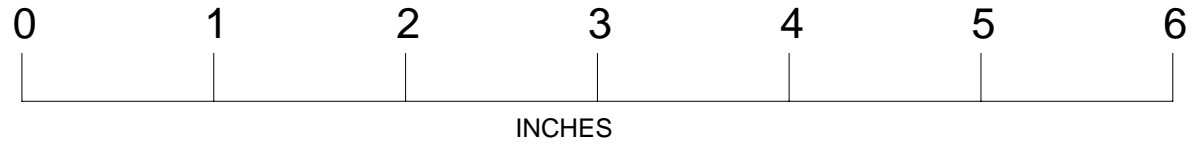
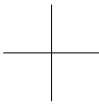



6
5
4
3
2
1
0

INCHES

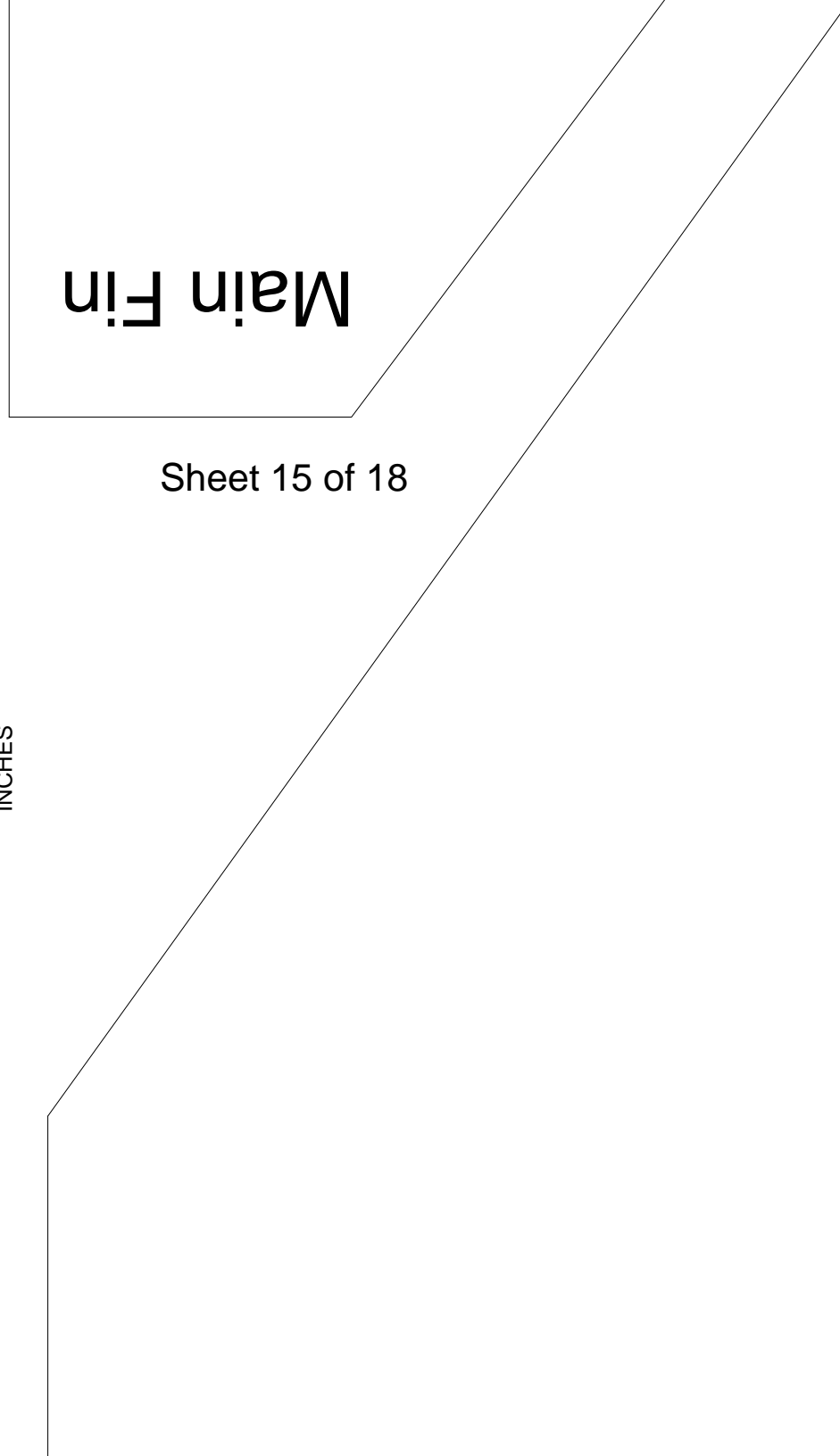

Main Fin

Sheet 15 of 18

Wing panel -
forward
center piece

Wing panel -
rear center
piece

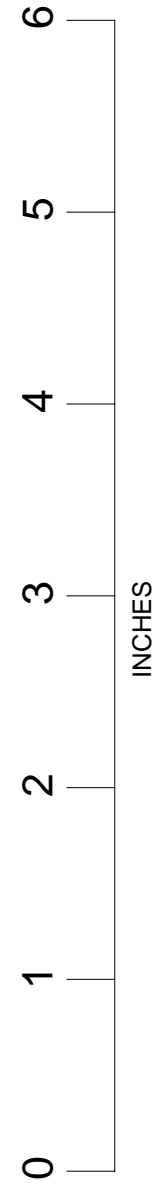

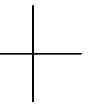
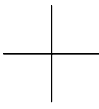

Wing panel - forward root piece

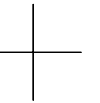
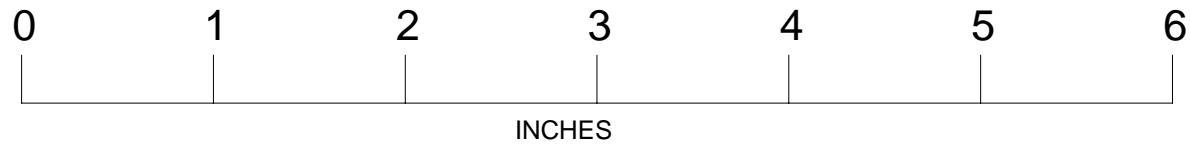
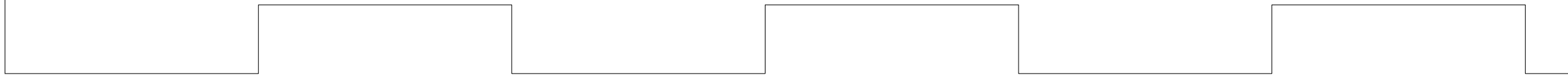

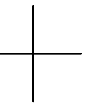
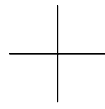

Wing panel -
rear root
piece

